

PROJECT MANUAL

For

Lander University

Brookside Building No. 7 Roof Replacement

Prepared for

Lander University

Prepared by



Delivery Order Project No. H21-P016-09

WM Project No. 2023-239

Construction Documents

Issued: October 12, 2023

TABLE OF CONTENTS

PROJECT NAME: Lander University – Brookside Building No. 7 Roof Replacement

DELIVERY ORDER PROJECT NUMBER: H21-P016-09

PROJECT NUMBER: WMBE 2023-239

SECTION

Table of Contents

Project Title Page (000101)

Document 001116 - Invitation to Bid

Asbestos Free Warranty

TECHNICAL SPECIFICATIONS

DIVISION 01 – GENERAL REQUIREMENTS

SECTION 011000 - SUMMARY
SECTION 012200 - UNIT PRICES

DIVISION 02 – EXISTING CONDITIONS

SECTION 024119 - SELECTIVE DEMOLITION

DIVISION 06 – WOOD AND PLASTICS

SECTION 061053 – MISCELLANEOUS ROUGH CARPENTRY

DIVISION 07 – THERMAL AND MOISTURE PROTECTION

SECTION 073113 – ARCHITECTURAL LAMINATED SHINGLES
SECTION 076200 – SHEET METAL FLASHING AND TRIM

DRAWINGS

SHEET R-1.0 - COVER PAGE
SHEET R-1.1 - SPECIFICATIONS
SHEET R-1.2 - SPECIFICATIONS
SHEET R-1.3 - LANDER UNIVERSITY CAMPUS MAP
SHEET R-2.1 – BROOKSIDE BUILDING NO. 7 EXISTING ROOF PLAN
SHEET R-2.2 – BROOKSIDE BUILDING NO. 7 NEW ROOF PLAN
SHEET D-1.1 - DETAILS
SHEET D-1.2 - DETAILS
SHEET D-1.3 - DETAILS

DOCUMENT 000101 - PROJECT TITLE PAGE

DESIGN DEVELOPMENT PROJECT MANUAL

Lander University

Building No. 7 Roof Replacement

Delivery Order Project Number: H21-P016-09

WMBE Project No. 2023-239



Daniel Atwell, RBEC (RRC, RWC, REWC), RRO, REWO, CDT

1611 Chapin Road

Chapin, SC 29036

Phone: (803) 422-7493

Daniel@wmbeconsultants.com

Issued: October 12, 2023

END OF DOCUMENT 000101

DOCUMENT 001116 - INVITATION TO BID

1.1 PROJECT INFORMATION

- A. Project Identification: Lander University – Brookside Building No. 7 Roof Replacement
- B. Owner: Lander University - 320 Stanley Ave, Greenwood, SC 29649
 - 1. Owner's Representative: Mr. Jeff Beaver – Director Office of Engineering Services
- C. Consultant: Daniel Atwell, WM Building Envelope Consultants, LLC, 1501 Chapin Road, Chapin, SC. Phone: 803-422-7493 or daniel@wmbeconsultants.com
- D. Project Description:
 - 1. Base Bid Work: Roof Replacement of the existing shingle roof system down to the existing roof decking at the site location as noted on the drawings. Roof replacement includes deck repairs, and installation of a new architectural asphalt shingle roof system. Associated sheet metal gutter and downspout system and other sheet metal components and accessories are included.
 - 2. The Contractor is to confirm all dimensions and square footages prior to providing bid.

1.2 PREBID CONFERENCE

- A. The non-mandatory Pre-Bid Meeting is scheduled for Thursday, November 02, 2023, at 10:00 am.
 - 1. Meeting Location:
 - a. Facility Operations Bldg.
 - b. Second Floor Conference Room
 - c. 204 West Henrietta Ave, Greenwood SC 29649
- B. Questions are due from the Contractor to the Roof Consultant on November 7, 2023, at 5:00 PM.

1.3 BID SUBMITTAL AND OPENING

- A. The owner will receive sealed bids until the bid time and date at the location indicated below. Owner will consider bids prepared in compliance with the Instructions to Bidders issued by Owner, and delivered as follows:
 - 1. Bid Date: November 14, 2023
 - 2. Bid Time: 3:00 p.m.
 - 3. Meeting Location:
 - a. Facility Operations Bldg.
 - b. Second Floor Conference Room

- c. 204 West Henrietta Ave, Greenwood SC 29649
- 4. Direct all bids to Mr. Jeff Beaver: Director Office of Engineering Services

1.4 DOCUMENTS

- A. Printed Procurement and Contracting Documents: Documents will be provided to the bidders at the pre-bid conference; only complete sets of documents will be issued.

1.5 TIME OF COMPLETION AND LIQUIDATED DAMAGES

- A. Bidders shall begin the Work on receipt of the Notice to Proceed and shall complete the Work within the Contract Time.

1.6 BIDDER'S QUALIFICATIONS

- A. Bidders must be properly licensed under the laws governing their respective trades and be able to obtain insurance and bonds required for the Work.

END OF DOCUMENT 001116

Asbestos Free Warranty

Project Identification: Lander University – Brookside Building No. 7 Roof Replacement

Agency: Lander University

Project Location: Lander University, 320 Stanley Avenue, Greenwood, SC 29649

Delivery Order Project Number: H21-P016-09

WMBE Project No. 2023-239

I, _____, certify that _____
(Company Representative) (Company Name)

to the best of the Contractor’s knowledge, did not intentionally or knowingly incorporate any asbestos containing materials (ACM) into this project at any time during the course of construction.

(Name and Title of Company Representative)

State of: _____

County of: _____

Subscribed and sworn to before _____, this ____ day of _____, 20__.

Notary Public: _____

My Commission Expires: _____

SECTION 011000 - SUMMARY

PART 1 - GENERAL

1.1 RELATED DOCUMENTS

- A. Drawings and general provisions of the Contract, including General and Supplementary Conditions and other Division 01 Specification Sections, apply to this Section.

1.2 SUMMARY

- A. Section Includes:

- 1. Project information.
- 2. Work covered by Contract Documents.
- 3. Access to site.
- 4. Coordination with occupants.
- 5. Work restrictions.

- B. Related Requirements:

- 1. Division 01 General Requirements: Requirements of Sections in Division 01 apply to the Work of all Sections in the Specifications.

1.3 PROJECT INFORMATION

- A. Project Identification: Lander University – Brookside Building No. 7 Roof Replacement

- 1. Project Location: Lander University - 320 Stanley Ave, Greenwood, SC 29649

- B. Owner: Lander University

- 1. Owner's Representative: Mr. Jeff Beaver – Director Office of Engineering Services

- C. Consultant: Daniel Atwell, WM Building Envelope Consultants, LLC, 1501 Chapin Road, Chapin, SC. Phone: 803-422-7493 or daniel@wmbeconsultants.com

1.4 GENERAL SUMMARY

- 1. Base Bid Work: Roof Replacement of the existing shingle roof system down to the existing roof decking at the site location as noted on the drawings. Roof replacement includes deck repairs, and installation of a new architectural asphalt shingle roof system. Associated sheet metal gutter and downspout system and other sheet metal components and accessories are included.
- 2. The Contractor is to confirm all dimensions and square footages prior to providing bid.

1.5 ACCESS TO SITE

- A. General: Contractor shall have limited use of Project site for construction operations. These locations will be determined at the pre-bid conference.
- B. Use of Site: Limit use of project site to areas of work. Do not disturb portions of project site beyond areas in which the Work is indicated.
 - 1. Limits: Confine construction operations to areas of work.
 - 2. Driveways, Walkways and Entrances: Keep driveways, loading areas, and entrances serving premises clear and available to Owner, Owner's employees, and emergency vehicles at all times. Do not use these areas for parking or storage of materials.
 - a. Schedule deliveries to minimize use of driveways and entrances by construction operations.
 - b. Schedule deliveries to minimize space and time requirements for storage of materials and equipment on-site.
- C. Condition of Existing Building: Maintain all areas of existing building affected by construction operations in a weathertight condition throughout construction period. Repair damage caused by construction operations.
 - a. Proper temporary protection of the gymnasium floors is required at all times during construction. Temporary protection may be required to be removed, both full or in part, to allow Owner temporary use.

1.6 COORDINATION WITH OCCUPANTS

- A. Full Owner Occupancy: Owner will occupy site and adjacent building(s) during portions of the construction period. Cooperate with Owner during construction operations to minimize conflicts and facilitate Owner usage. Perform the Work so as not to interfere with Owner's day-to-day operations. Maintain existing exits unless otherwise indicated.
 - 1. Maintain access to existing walkways, corridors, and other adjacent occupied or used facilities. Do not close or obstruct walkways, corridors, or other occupied or used facilities without written permission from Owner and approval of authorities having jurisdiction.
 - 2. Notify Owner not less than 72 hours in advance of activities that will affect Owner's operations.

1.7 WORK RESTRICTIONS

- A. Work Restrictions, General: Comply with restrictions on construction operations.
 - 1. Comply with limitations on use of public streets and with other requirements of authorities having jurisdiction.

2. Comply with limitations during scheduled exam testing times.
- B. On-Site Work Hours: Monday – Friday (7am – 5pm) Limit work on the existing building to normal business working hours, Monday through Friday, unless otherwise approved by owner.
1. Weekend Hours: Weekend work must be coordinated and approved by the Owner minimum of 48 hours prior to requested date.
 2. Early Morning Hours: Work occurring during early morning hours must be coordinated and approved by the Owner.
- C. Existing Utility Interruptions: Do not interrupt utilities serving facilities occupied by Owner or others unless permitted under the following conditions and then only after providing temporary utility services according to requirements indicated:
1. Notify Consultant and Owner not less than 72 hours in advance of proposed utility interruptions.
 2. Obtain Owner’s written permission before proceeding with utility interruptions.
- D. Noise, Vibration, and Odors: Coordinate operations that may result in high levels of noise and vibration, odors, or other disruption to Owner occupancy with Owner.
- E. Nonsmoking / tobacco: Smoking / tobacco is not permitted on the campus.
- F. Controlled Substances: Use of tobacco products and other controlled substances is not permitted.
- G. Employee Identification: Provide identification tags for Contractor personnel working on Project site. Require personnel to use identification tags at all times.
- H. Employee Screening: Comply with Owner's requirements for drug and background screening of Contractor personnel working on Project site.
1. Maintain list of approved screened personnel with Owner's representative.

PART 2 - PRODUCTS (Not Used)

PART 3 - EXECUTION (Not Used)

END OF SECTION 011000

SECTION 012200 - UNIT PRICES

PART 1 - GENERAL

1.1 RELATED DOCUMENTS

- A. Drawings and general provisions of the Contract, including General and Supplementary Conditions and other Division 01 Specification Sections, apply to this Section.

1.2 SUMMARY

- A. Section includes administrative and procedural requirements for unit prices.

1.3 DEFINITIONS

- A. Unit price is a price per unit of measurement for materials, equipment, or services, or a portion of the Work, added to or deducted from the Contract Sum by appropriate modification, if the scope of Work or estimated quantities of Work required by the Contract Documents are increased or decreased.
- B. Contractor to provide the requested cost per unit prices category. Contractor shall notify Consultant and Owner upon discovery and include the following with payment request.
 - 1. Photo documentation shall be upon required.
 - 2. Invoice receipt shall be required upon request.

1.4 PROCEDURES

- A. Unit prices include all necessary material, plus cost for delivery, installation, insurance, applicable taxes, overhead, and profit.
- B. Measurement and Payment: See individual Specification Sections for work that requires establishment of unit prices. Methods of measurement and payment for unit prices are specified in those Sections.
- C. Owner reserves the right to reject Contractor's measurement of work-in-place that involves use of established unit prices and to have this work measured, at Owner's expense, by an independent surveyor acceptable to Contractor.
- D. The Contractor is required to notify the Consultant, in writing, when approximately 75% of unit price quantities have been used.
- E. List of Unit Prices: A schedule of unit prices is included in Part 3. Specification Sections referenced in the schedule contain requirements for materials described under each unit price.

PART 2 - PRODUCTS (Not Used)

PART 3 - EXECUTION

3.1 SCHEDULE OF UNIT PRICES TO BE INCLUDED IN THE BASE BID

A. Unit Price No. 4: 5/8 CDX Plywood Deck Replacement

1. 192 SF (six sheets)

B. Unit Price No. 6: Soffit System Vinyl Replacement

1. 50 LF

END OF SECTION 012200

SECTION 024119 - SELECTIVE DEMOLITION

PART 1 - GENERAL

1.1 RELATED DOCUMENTS

- A. Drawings and general provisions of the contract, including the General and Supplemental Conditions, as well as other Division 01 Specification Sections, apply to this section.

1.2 SUMMARY

- A. Section Includes:

- 1. Demolition and removal of select existing shingle roof system and existing waterproof underlayment / felt down to the roof deck for replacement with a new architectural laminated asphalt shingle system.
- 2. Removal of all existing sheet metal flashings and all associated components area to be replaced with new (eave, rake, flashings, etc.)

1.3 DEFINITIONS

- A. Remove: Detach items from existing construction and legally dispose of them off-site unless indicated to be removed and salvaged or removed and reinstalled.
- B. Remove and Reinstall: Detach items from existing construction, prepare for reuse, and reinstall where indicated.
- C. Existing to Remain: Existing items of construction that are not to be permanently removed and that are not otherwise indicated to be removed, removed and salvaged, or removed and reinstalled.

1.4 INFORMATIONAL SUBMITTALS

- A. Predemolition Photographs or Video: Submit before Work begins.

1.5 FIELD CONDITIONS

- A. Owner will occupy portions of building immediately adjacent to selective demolition area. Conduct selective demolition so Owner's operations will not be disrupted.
- B. Conditions existing at time of inspection for bidding purpose will be maintained by Owner as far as practical.

- C. Notify Consultant of discrepancies between existing conditions and Drawings before proceeding with selective demolition.
- D. If any suspected hazardous materials are encountered, do not disturb; immediately notify Consultant and Owner. Hazardous materials will be removed by Owner under a separate contract.
- E. Storage or sale of removed items or materials on-site is not permitted.
- F. Utility Service: Maintain existing utilities indicated to remain in service and protect them against damage during selective demolition operations.
 - 1. Maintain fire-protection facilities in service during selective demolition operations.

PART 2 - PRODUCTS

2.1 PERFORMANCE REQUIREMENTS

- A. Regulatory Requirements: Comply with governing EPA notification regulations before beginning selective demolition. Comply with hauling and disposal regulations of authorities having jurisdiction.
- B. Standards: Comply with ANSI/ASSE A10.6 and NFPA 241.

PART 3 - EXECUTION

3.1 EXAMINATION

- A. Verify that utilities have been disconnected and capped before starting selective demolition operations.
- B. Survey existing conditions and correlate with requirements indicated to determine extent of selective demolition required.
- C. When unanticipated mechanical, electrical, or structural elements that conflict with intended function or design are encountered, investigate and measure the nature and extent of conflict. Promptly submit a written report to Consultant.
- D. Engage a professional engineer (if any structural element will be modified, removed, and/or addressed) to perform an engineering survey of condition of building to determine whether removing any element might result in structural deficiency or unplanned collapse of any portion of structure or adjacent structures during selective building demolition operations.
- E. Survey of Existing Conditions: Record existing conditions by use of preconstruction photographs

3.2 UTILITY SERVICES AND MECHANICAL/ELECTRICAL SYSTEMS

- A. Existing Services/Systems to Remain: Maintain services/systems indicated to remain and protect them against damage.
 - 1. Comply with requirements for existing services/systems interruptions specified in Section 011000 "Summary."

3.3 PREPARATION

- A. Site Access and Temporary Controls: Conduct selective demolition and debris-removal operations to ensure minimum interference with roads, streets, walks, walkways, and other adjacent occupied and used facilities.
- B. Temporary Facilities: Provide temporary barricades and other protection required to prevent injury to people and damage to adjacent buildings and facilities to remain.
- C. Temporary Shoring: Provide and maintain shoring, bracing, and structural supports as required to preserve stability and prevent movement, settlement, or collapse of construction and finishes to remain, and to prevent unexpected or uncontrolled movement or collapse of construction being demolished.

3.4 SELECTIVE DEMOLITION, GENERAL

- A. General: Demolish and remove existing roof system only to the extent required by new roof system and as indicated. Use methods required to complete the Work within limitations of governing regulations and as follows:
 - 1. Use cutting methods least likely to damage construction to remain or adjoining construction. Use hand tools or small power tools designed for sawing or grinding, not hammering and chopping, to minimize disturbance of adjacent surfaces. Temporarily cover openings to remain.
 - 2. Cut or drill from the exposed or finished side into concealed surfaces to avoid marring existing finished surfaces.
 - 3. Remove all existing fasteners utilizing mechanical drills.
 - 4. Do not use cutting torches or flame / fire related tools.
 - 5. Locate selective demolition equipment and remove debris and materials so as not to impose excessive loads on supporting walls, floors, or framing.
 - 6. Remove all demolished items from roof in a manner to not damage exterior of facility and select locations determined by Owner.
- B. Removed and Reinstalled Items:
 - 1. Clean and repair items to functional condition adequate for intended reuse.

2. Pack or crate items after cleaning and repairing. Identify contents of containers.
 3. Protect items from damage during transport and storage.
 4. Reinstall items in locations indicated. Comply with installation requirements for new materials and equipment. Provide connections, supports, and miscellaneous materials necessary to make item functional for use indicated.
- C. Existing Items to Remain: Protect construction indicated to remain against damage and soiling during selective demolition.

3.5 DISPOSAL OF DEMOLISHED MATERIALS

- A. General: Except for items or materials indicated to be recycled, reused, salvaged, reinstalled, or otherwise indicated to remain Owner's property, remove demolished materials from Project site and legally dispose of them in an approved landfill.
1. Do not allow demolished materials to accumulate on-site.
 2. Remove and transport debris in a manner that will prevent spillage on adjacent surfaces and areas.
 3. Remove debris from elevated portions of building by chute, hoist, or other device that will convey debris to grade level in a controlled descent.
- B. Burning: Do not burn demolished materials.
- C. Disposal: Transport demolished materials off Owner's property and legally dispose of them.

3.6 CLEANING

- A. Clean adjacent structures and improvements of dust, dirt, and debris caused by selective demolition operations. Return adjacent areas to condition existing before selective demolition operations began.

END OF SECTION 024119

SECTION 061053 - MISCELLANEOUS ROUGH CARPENTRY

PART 1 - GENERAL

1.1 RELATED REQUIREMENTS

- A. Drawings and general provisions of the contract, including the General and Supplemental Conditions, as well as other Division 01 Specification Sections, apply to this section.

1.2 SUMMARY

- A. Section Includes:

- 1. A unit price is required to be provided if existing wood products that are found to be damaged/deteriorated and cannot be reused.
- 2. Replacement of all rotted/deteriorated/deformed wood decking.

1.3 DEFINITIONS

- A. Lumber: Minimum 2 inches x 6 inches unless otherwise indicated.
- B. All wood products being replaced shall match the sizes and configurations of existing components.
- C. Lumber grading agencies, and the abbreviations used to reference them, include the following:
 - 1. NLGA: National Lumber Grades Authority.
 - 2. SPIB: The Southern Pine Inspection Bureau.

1.4 ACTION SUBMITTALS

- A. Product Data: For each type of process and factory-fabricated product. Indicate component materials and dimensions and include construction and application details.

1.5 INFORMATIONAL SUBMITTALS

- A. Evaluation Reports: For the following, from ICC-ES:
 - 1. Preservative-treated wood.
 - 2. Power-driven fasteners.
 - 3. Powder-actuated fasteners.
 - 4. Expansion anchors.

1.6 QUALITY ASSURANCE

- A. Testing Agency Qualifications: For testing agency providing classification marking for fire-retardant treated material, an inspection agency acceptable to authorities having jurisdiction that periodically performs inspections to verify that the material bearing the classification marking is representative of the material tested.

1.7 DELIVERY, STORAGE, AND HANDLING

- A. Stack lumber flat with spacers beneath and between each bundle to provide air circulation. Protect lumber from weather by covering with waterproof sheeting, securely anchored. Provide for air circulation around stacks and under coverings.

PART 2 - PRODUCTS

2.1 WOOD PRODUCTS, GENERAL

- A. Lumber: DOC PS 20 and applicable rules of grading agencies indicated. If no grading agency is indicated, provide lumber that complies with the applicable rules of any rules-writing agency certified by the ALSC Board of Review. Provide lumber graded by an agency certified by the ALSC Board of Review to inspect and grade lumber under the rules indicated.
 - 1. Factory mark each piece of lumber with grade stamp of grading agency.
 - 2. For exposed lumber indicated to receive a stained or natural finish, mark grade stamp on end or back of each piece.
- B. Maximum Moisture Content of Lumber: 15 percent for 2-inch nominal thickness or less, 19 percent for more than 2-inch nominal thickness unless otherwise indicated.

2.2 WOOD-PRESERVATIVE-TREATED MATERIALS

- A. Preservative Treatment by Pressure Process: AWWA U1; Use Category UC3b.
 - 1. Preservative Chemicals: Acceptable to authorities having jurisdiction and containing no arsenic or chromium.
 - 2. For exposed items indicated to receive a stained or natural finish, use chemical formulations that do not require incising, contain colorants, bleed through, or otherwise adversely affect finishes.
- B. Kiln-dry lumber after treatment to a maximum moisture content of 19 percent. Do not use material that is warped or does not comply with requirements for untreated material.
- C. Mark lumber with treatment quality mark of an inspection agency approved by the ALSC Board of Review.
 - 1. For exposed lumber indicated to receive a stained or natural finish, mark end or back of each piece.

2.3 DIMENSIONAL LUMBER

- A. Framing/Wood Blocking/Nailers:
 - 1. Construction or No. 2 Southern pine (SPIB).
 - 2. Pressure Treated, kiln dried, intended for ground contact.
 - 3. Maximum Moisture Content of Lumber: 19 percent or less.
 - 4. Minimum 2" x 6" unless approved otherwise.

2.4 PLYWOOD

- A. APA classification C-D, Exposure 1.
 - 1. Thickness shall be match existing.
 - 2. Maximum Moisture Content of Plywood: 15 percent or less

2.5 FASTENERS

- A. General: Provide fasteners of size and type indicated that comply with requirements specified in this article for material and manufacture. Fasteners shall be compatible with the wood treatment used.
 - 1. Where carpentry is exposed to weather, in ground contact, pressure-preservative treated, or in area of high relative humidity, provide fasteners of Type 304 stainless steel.
 - 2. For wood blocking attachment to steel, use a minimum of #12 stainless steel self-drilling fastener to penetrate steel structure below the nailer a minimum of 1" depth. Wood blocking shall be attached at the fastener rate indicated in Part 3 of this specification section. One fastener shall be at a maximum of 4" from board end.
 - 3. Provide a self-adhering underlayment between treated wood blocking and any sheet metal products including the counterflashing, etc.
 - 4. If other substrate/edge conditions exist, the Contractor shall provide attachment to resist 250 pounds per square linear foot in all directions and increased by 100% at corners.

2.6 UNDERLAYMENT

- A. Self-Adhering Underlayment: Composite, self-adhesive, flashing product consisting of a pliable, butyl rubber or rubberized-asphalt compound, bonded to a high-density polyethylene film, aluminum foil, or spunbonded polyolefin to produce an overall thickness of not less than 36 mils.

PART 3 - EXECUTION

3.1 INSTALLATION, GENERAL

- A. Set carpentry to required levels and lines, with members plumb, true to line, cut, and fitted. Fit carpentry to other construction; scribe and cope as needed for accurate fit.

- B. Where wood-preservative-treated lumber is installed adjacent to metal decking, install continuous self-adhering underlayment separator between wood and metal decking.
- C. Framing Standard: Comply with AF&PA's WCD 1, "Details for Conventional Wood Frame Construction," unless otherwise indicated.
- D. Do not splice structural members between supports unless otherwise indicated.
- E. Sort and select lumber so that natural characteristics will not interfere with installation or with fastening other materials to lumber. Do not use materials with defects that interfere with function of member or pieces that are too small to use with minimum number of joints or optimum joint arrangement.
- F. Comply with AWWA M4 for applying field treatment to cut surfaces of preservative-treated lumber.
 - 1. Use inorganic boron for items that are continuously protected from liquid water.
 - 2. Use copper naphthenate for items not continuously protected from liquid water.
- G. For plywood attachment to existing wood trusses, fasteners shall be attached 4" O.C. around the perimeter of sheathing and 6" O.C. in the field. Fasteners shall penetrate into the existing supports a minimum of 1". The spacing of the fasteners shall be at all truss/rafter/support locations.
- H. Securely attach carpentry work to substrate by anchoring and fastening as indicated, complying FM Loss Protection Data Sheet 1-49 and with the following:
 - 1. Wood to Wood:
 - a. (30 PSF – 52.5 PSF) Two staggered rows of fasteners spaced 24 inches on center in Zone 2 and 12 inches on center for Zone 3.
 - b. (60 PSF) Two staggered rows of fasteners spaced 22 inches on center in Zone 2 and 12 inches on center for zone 3.
 - c. (67.5 PSF) Two staggered rows of fasteners spaced 20 inches on center in Zone 2 and 12 inches on center for zone 3.
 - d. (75 PSF) Two staggered rows of fasteners spaced 18 inches on center in Zone 2 and 12 inches on center for zone 3.
 - e. (82.5 PSF) Two staggered rows of fasteners spaced 16 inches on center in Zone 2 and 10 inches on center for zone 3.
 - f. (90 PSF) Two staggered rows of fasteners spaced 14 inches on center in Zone 2 and 10 inches on center for zone 3.
 - g. (97.5 PSF) Two staggered rows of fasteners spaced 14 inches on center in Zone 2 and 8 inches on center for zone 3.
 - h. (105 PSF – 112.5 PSF) Two staggered rows of fasteners spaced 12 inches on center in Zone 2 and 8 inches on center for zone 3.
 - i. (120 PSF – 135 PSF) Two staggered rows of fasteners spaced 10 inches on center in Zone 2 and 6 inches on center for zone 3.

END OF SECTION 061053

SECTION 073113 – ARCHITECTURAL LAMINATED SHINGLES

PART 1 - GENERAL

1.1 RELATED DOCUMENTS

- A. Drawings and general provisions of the Contract, including General and Supplementary Conditions and Division 01 Specification Sections, apply to this Section.

1.2 SUMMARY

A. Section Includes:

1. Remove and dispose of existing shingle roof system down to the existing roof deck.
2. Provide shingle underlayment system, eave and ridge ventilation, sheet metal flashing and trim to provide a watertight, warrantable roof system.
3. New gutter and downspout system and all associated sheet metal details to be installed as shown on the new drawing pages.
4. Provide one (1) additional square of architectural laminated asphalt shingles for Owner's attic stock upon completion of the project. Coordinate storage location with Owner.

B. Related Sections:

1. Section 061053 "Miscellaneous Rough Carpentry"
2. Section 076200 "Sheet Metal Flashing and Trim"

1.3 REFERENCES

- A. AMERICAN SOCIETY OF CIVIL ENGINEERS - Reference Document ASCE 7, Minimum Design Loads for Buildings and Other Structures.
- B. ASPHALT ROOFING MANUFACTURERS ASSOCIATION (ARMA):
- C. AMERICAN STANDARD OF TESTING METHODS (ASTM):
 1. ASTM A653/A653M - Standard Specification for Steel Sheet, Zinc Coated (Galvanized) or Zinc-Iron Alloy-Coated (Galvannealed) by the Hot-Dip Process.
 2. ASTM B209 - Standard Specification for Aluminum and Aluminum-Alloy Sheet and Plate.
 3. ASTM D226 - Standard Specification for Asphalt-Saturated Organic Felt Used in Roofing and Waterproofing.
 4. ASTM D228 - Standard Test Method for Sampling, Testing, and Analysis of Asphalt Roll Roofing, Cap Sheets, and Shingles Used in Roofing and Waterproofing.

5. ASTM D1079 – Standard Terminology Relating to Roofing and Waterproofing.
6. ASTM D1970 - Standard Specification for Self-Adhering Polymer Modified Bituminous Sheet Materials Used as Steep Roofing Underlayment for Ice Dam Protection.
7. ASTM D3018 - Standard Specification for Class A Asphalt Shingles Surfaced with Mineral Granules.
8. ASTM D3161 - Standard Test Method for Wind-Resistance of Asphalt Shingles (Fan-Induced Method).
9. ASTM D3462 - Standard Specification for Asphalt Shingles Made from Glass felt and Surfaced with Mineral Granules.
10. ASTM D 4586 - Standard Specification for Asphalt Roof Cement, Asbestos-Free.
11. ASTM D4869 - Standard Specification for Asphalt-Saturated Organic Felt Underlayment Used in Steep Slope Roofing.
12. ASTM D6381 - Standard Test Method for Measurement of Asphalt Shingle Mechanical Uplift Resistance.
13. ASTM D6757 - Standard Specification for Underlayment Felt Containing Inorganic Fibers Used in Steep-Slope Roofing.
14. ASTM D7158 - Standard Test Method for Wind Resistance of Sealed Asphalt Shingles (Uplift Force/Uplift Resistance Method).
15. ASTM E108 - Standard Test Methods for Fire Tests of Roof Coverings.
16. ASTM F1667 - Standard Specification for Driven Fasteners: Nails, Spikes, and Staples.
17. ASTM D6163 - Standard Specification for Styrene Butadiene Styrene (SBS) Modified Bituminous Sheet Materials Using Glass Fiber Reinforcements.
18. ASTM D6164 – Standard Specification for Styrene Butadiene Styrene (SBS) Modified Bituminous Sheet Materials Using Polyester Reinforcements.

D. INTERNATIONAL CODES COUNCIL (ICC):

1. 2018 International Building Code (IBC).

E. NATIONAL ROOFING CONTRACTORS ASSOCIATION (NRCA).

F. SHEET METAL AND AIR CONDITIONING CONTRACTORS NATIONAL ASSOCIATION INC. (SMACNA) Architectural Sheet Metal Manual.

G. UNDERWRITERS LABORATORY (UL):

1. UL 790 Standard Test Methods for Fire Tests of Roof Coverings.
2. UL 997 – Wind Resistance of Prepared Roof Covering Materials.
3. UL 2218 - Impact Resistance of Prepared Roof Covering Materials.
4. UL 2390 - Test Method for Wind Resistant Asphalt Shingles with Sealed Tabs.
5. UL 1897 – Uplift Tests for Roof Covering Systems.

1.4 REGULATORY REQUIREMENTS

- A. Provide a roofing system having an Underwriters Laboratories (UL) Class A fire resistance classification.
- B. Install all roofing products in accordance with all federal, state and local building codes.
- C. All work shall be performed in a manner consistent with current OSHA guidelines.

1.5 ACTION SUBMITTALS

- A. No work shall begin until all submittals have been received, approved, and Pre-Construction Conference has been completed.
- B. Product Data Sheets: Submit manufacturer's product data sheets, installation instructions, and general requirements for all roof system components.
- C. Provide manufacturer's Material Safety Data Sheets (SDS) for all roof system components.
- D. Sample Warranty from the manufacturer and contractor.
- E. Shop Drawings: Provide roof plan and applicable roof system detail drawings.
- F. Provide written certification from the roofing system manufacturer certifying the following:
 - 1. The installer of the materials is authorized by the manufacturer to install the specified materials and can provide the required warranty.
 - 2. Provide written certification from the roofing system manufacturer stating that all materials meet the specified requirements and that all materials are compatible with each other.
 - 3. Certify that all products provided and used are manufactured in the United States.

1.6 CONTRACTOR QUALIFICATIONS

- A. Contractor shall be authorized by the manufacturer to install specified materials prior to the bidding period through satisfactory project completion.
- B. Applicators shall have completed projects of similar scope using same materials as specified herein.
- C. Contractor shall provide full time, on-site superintendent or foreman experienced with the specified roof system through satisfactory project completion.
- D. Applicators shall be skilled in the application methods for all materials.
- E. Contractor shall maintain a daily record, on-site, documenting material installation and related project conditions.
- F. Contractor shall maintain a copy of all submittal documents, on-site, available at all times for reference.

1.7 CLOSEOUT SUBMITTALS

- A. Maintenance Data: For shingle roof system and its accessories, to include in maintenance manuals.
- B. Furnish a Two (2) year contractor warranty and a life-time manufacturer's warranty.

- C. Contractor to provide a minimum of one (1) square of architectural laminated asphalt shingles, same as used on the project, for Owner's attic stock.

1.8 QUALITY ASSURANCE

A. Contractor Qualifications:

1. Contractor shall be approved by the roofing system manufacturer to install the manufacturer's product and that is eligible to receive the specified manufacturer's warranty.
2. Contractor shall also have applied 5 installations of similar size and scope within the previous 5 years.

B. Manufacturer Qualifications:

1. All products and materials shall have UL approval.
2. All products and materials shall be manufactured in the United States.
3. The roofing system manufacturer shall have a minimum of ten (10) years' experience in manufacturing asphalt shingle roofing products in the United States.
4. All products used in the system shall be labeled by or approved for use by the manufacturer issuing the guarantee.

1.9 DELIVERY, STORAGE, AND HANDLING

- A. Deliver roofing materials in their original unbroken bundles and labeled with manufacturer's name, product brand name and type, date of manufacture, and directions for storage.
- B. Protect roofing materials from physical damage and from deterioration by sunlight, moisture, soiling, and other sources. Comply with insulation manufacturer's written instructions for handling, storing, and protecting during installation.
- C. Store asphalt shingles on flat surfaces. When placing on the roof, do not place shingles bent over ridges, hips or any other surfaces that are not flat.
- D. Handle and store roofing materials and place materials in a manner to avoid permanent deflection or damage to the roof deck or roof deck components.

1.10 PROJECT CONDITIONS

- A. Proceed with installation only when current and forecasted weather conditions permit roofing system to be installed in accordance with manufacturer's written instructions.

1.11 WARRANTY

- A. Provide manufacturer's minimum 40-year warranty. Manufacturer's warranty shall include all materials manufactured by the roof system manufacturer or labeled with the manufacturer's name.

- B. Provide Roofing Contractor's 2-year warranty for the roof system. The 2-year warranty period will be from the substantial completion date. The Roofing Contractor's 2-year warranty shall be signed and will include all components of the roofing system for the warranty period.

PART 2 - PRODUCTS

2.1 PERFORMANCE REQUIREMENTS

- A. Material Compatibility: Roofing materials shall be compatible with one another and adjacent materials under conditions of service and application required, as demonstrated by roofing manufacturer based on testing and field experience.
- B. Laminated Asphalt Shingles: ASTM D3462, laminated, multi-ply construction, glass-fiber reinforced, mineral-granule surfaced, and self-sealing.
- C. Manufacturers:
 - 1. GAF Timberline HD / HDz
 - 2. CertainTeed Landmark Pro
 - 3. Owens Corning Duration
 - 4. Approved Equal By Consultant.
- D. Laminated Architectural Shingles shall meet the following minimum requirements:
 - 1. ASTM D3018, Type 1.
 - 2. ASTM D3462.
 - 3. ASTM D3161, Class F Wind Resistance.
 - 4. ASTM D7158, Class H Wind Resistance.
 - 5. ASTM E108/UL 790, Class A Fire Resistance.
 - 6. Algae Resistant for a period of 10 years.
- E. Fire-Resistance Ratings: Comply with fire-resistance-rated assembly indicated. Identify products with appropriate markings of applicable testing agency.
- F. The ridge ventilation system shall allow for a minimum of 1 sq. ft. of net free area of ventilation to every 150 feet of attic floor space.

2.2 ARCHITECTURAL LAMINATED SHINGLE ROOF DESCRIPTION

- A. Architectural Laminated Asphalt Shingles: ASTM D3462, laminated, multi-ply construction, glass-fiber reinforced, mineral-granule surfaced, and self-sealing.

2.3 UNDERLAYMENT MATERIALS

- A. Self-Adhering, High-Temperature Sheet: Minimum 40 mils thick, consisting of a slip-resistant polyethylene- or polypropylene-film top surface laminated to a layer of butyl- or SBS-modified asphalt adhesive, with release-paper backing; specifically designed to withstand high metal temperatures in contact with sheet metal components. Provide primer according to written recommendations of underlayment manufacturer.
 - 1. Thermal Stability: ASTM D 1970; stable after testing at 240 deg F or higher.
 - 2. Low-Temperature Flexibility: ASTM D 1970; passes after testing at minus 20 deg F or lower.
- B. Felt Underlayment: Minimum No. 30 asphalt saturated, non-perforated, organic felt meeting ASTM D 226, Type II.

2.4 MISCELLANEOUS MATERIALS

- A. Hip and Ridge Shingles: Use the manufacturer’s factory fabricated hip and ridge pieces as recommended by the roof system manufacturer to adhere to the specified requirements.
- B. Starter Shingles: Use the manufacturer’s factory fabricated starter shingles as recommended by the roof system manufacturer to adhere to the specified requirements.
- C. Ridge vents: Minimum 12 inch wide, interlocking, polypropylene ridge vent designed to work with eave/soffit intake ventilation to maximize air flow through the roof and attic structure. Shall pass wind-driven rain with 8.8 in of rain/hr. at 110 mph. The ventilation system shall allow for a minimum of 1 sq. ft. of net free area of ventilation to every 150 feet of attic space.
- D. Attic Insulation Rafter Baffles: Break-resistant, extruded polystyrene foam, sized to fit between framing members to assure maximum unrestricted airflow from the soffit to the ridge vent.
- E. Fasteners: Hot-dip galvanized, complying with ASTM F1667, minimum 12-gauge, ring shank with 3/8 -7/16 inch diameter head. Fastener shall be of sufficient length to penetrate a minimum of 3/4 inch into wood decking or penetrate just through the bottom of the wood decking. Electroplated galvanized fasteners are not permitted for use.
- F. Asphalt Roof Cement: ASTM D 4586, Type I or II asbestos free, compatible with roofing system and associated components.
- G. Plumbing Vent Flashings: Lead, minimum 4 lb., sizes to match pipe sizes, painted to match roofing color. Or pre-manufacture pipe boot as covered under manufacturer warranty.
- H. Elastomeric Sealant: ASTM C 920, elastomeric polyurethane polymer sealant; of type, grade, class, and use classifications required to seal joints in sheet metal flashing and trim and remain watertight.

PART 3 - EXECUTION

3.1 INSTALLATION, GENERAL

- A. Install architectural laminated shingles in accordance with the manufacturer's installation instructions and the Construction Documents.

3.2 SUBSTRATE PREPERATION

- A. Examine deck and other substrates for compliance with requirements affecting performance of roofing system.
- B. Verify that the deck is dry, structurally sound, clean and smooth. Deck shall be free of any depressions, waves, and projections. Cover all holes 1 inch or less in diameter, cracks over 1/2 in in width, loose knots and excessively resinous areas with minimum 28 gauge galvanized steel sheet metal. Decking or deck boards with holes greater than 1 inch in diameter shall be replaced.
- C. Ensure substrate has been properly prepared prior to installation of roofing materials. Do not proceed with installation until all conditions affecting proper installation have been corrected.
- D. Remove existing wall and trim materials as necessary to install underlayment and flashing materials. Properly reinstall materials removed upon completion of work.
- E. Clean and remove from substrate, dust, debris, moisture, and other substances detrimental to roofing installation.

3.3 UNDERLAYMENT INSTALLATION

- A. On slopes 4:12 or greater:
 - 1. Install self-adhering underlayment, wrinkle free, at eave, rakes valleys, hips, ridges, penetrations and terminations. Apply in shingle fashion to shed water with end laps of not less than 6 inches staggered between courses. Overlap side edges not less than 3-1/2 inches. Roll laps and edges with roller. Cover underlayment within 14 days.
 - a. At eave conditions, self-adhering underlayment shall extend from the lowest edge of the roof surface to a point not less than 24 inches inside the exterior wall line of the building. Install in water shedding fashion over the drip edge.
 - b. At rake conditions, provide full roll of self-adhering underlayment under drip edge.
 - c. Where self-adhering underlayment terminates into a roof penetration or wall, turn underlayment up the wall or penetration a minimum of 5 inches and out onto the roof a minimum of 12 inches unless otherwise recommended by the roof system manufacturer.
 - 2. Install a single layer of #30 underlayment over the prepared substrate in shingle fashion lapped a minimum of 3 inches, in accordance with the manufacturer's requirements and in accordance with local building code requirements.

- B. On slopes less than 4:12:
 - 1. Install self-adhering underlayment, wrinkle free, over the entire roof deck. Self-adhering underlayment shall be a full 36 inches wide. Apply in shingle fashion to shed water with end laps of not less than 6 inches staggered between courses. Overlap side edges not less than 3-1/2 inches.
 - 2. Lap ends a minimum of 6 inches and seal. Where Self-adhering underlayment terminates into a roof penetration or wall, turn underlayment up the wall or penetration a minimum of 5 inches.
 - 3. Roll laps and edges with roller. Cover underlayment within 14 days.
- C. Metal drip edge shall be installed on all roof edges. Install drip edge on eaves first with underlayment installed over the drip edge. Install drip edge on rakes after underlayment is installed, with the drip edge fastened over the underlayment. Joints in drip edge shall be lapped minimum of 3 inches and sealed with the upslope piece lapped over the down slope piece. Metal drip edge shall be fastened a minimum of 6 inches on center, approximately 1-3/4 inches to 2 inches from the outside edge of the drip edge.

3.4 ARCHITECTURAL LAMINATED SHINGLE INSTALLATION

- A. Install roofing system in accordance with roofing system manufacturer's written instructions, with NRCA and ARMA printed recommendations and the requirements in this Section.
- B. Coordinate installing roofing system so that the components of the roofing system system are not exposed or subjected to precipitation/inclement weather or left uncovered at the end of the workday.
- C. Install starter course at roof eave and along rake with edge of shingles extending 1/4 in over edge of roof. Sealant strip should be closest to roof edge.
- D. Install first and successive courses of shingles stepping diagonally up and across roof deck with manufacturer's recommended offset at each succeeding course. Maintain uniform exposure of shingles at each succeeding course. Use of a chalk line every other course to ensure straight installation.
- E. Fasten shingles to deck with a minimum of 6 fasteners per shingle. Fasten shingles in accordance with the shingle manufacturer's installation instructions and so that all layers are secured.
- F. All fasteners shall penetrate at least 3/4 in into the wood deck. Where the deck is less than 3/4 in thick, the fastener should be long enough to penetrate fully and extend through the underside of the roof deck. Fasteners shall be driven flush with the shingle surface and not be under driven or over driven.
- G. Install shingles at valleys, eaves, rakes, hips and ridges in accordance with the shingle manufacturer's installation instructions.
- H. Closed-Cut and Open Valleys: Comply with NRCA and ARMA recommendations.
- I. Install manufacturer's prefabricated ridge and hip caps in strict accordance with the manufacturers printed instructions and to provide proper venting and a watertight detail.

- J. Install ridge vents in strict accordance with the manufacturers printed instructions and to provide proper venting and a watertight detail.

3.5 FIELD QAULTY CONTROL

- A. Contractor to arrange for roofing system manufacturer's to inspect roofing installation during the course of the project and provide reports to Consultant and Owner.
- B. Repair or replace components of roofing system where test results or inspections indicate that they do not comply with the contract documents.
- C. If repairs or replacements made are not in accordance with the contract documents and additional testing and/or inspections are required, the cost for these services will be at the expense of the Contractor until the deficient item/items noted meet the requirements of the contract documents.

3.6 PROTECTION AND CLEANING

- A. Protect the roofing system from damage and wear during the course of construction.
- B. Clean grounds free of all nails, sheet metal, shingles and other shingle accessories each day.
- C. Clean all marks left on surfaces from roofing materials from building and surrounding grounds using cleaning agents and procedures recommended by manufacturer of affected construction.

END OF SECTION 073113

SECTION 076200 - SHEET METAL FLASHING AND TRIM

PART 1 - GENERAL

1.1 RELATED DOCUMENTS

- A. Drawings and general provisions of the Contract, including General and Supplementary Conditions and Division 01 Specification Sections, apply to this Section.

1.2 SUMMARY

- A. Section Includes:

- 1. Provide sheet metal flashings and trim as indicated in the Contract Drawings.
- 2. New sheet metal gutter system and downspouts shall be installed as indicated in drawings and drawing details.

- B. Related Sections:

- 1. Section 061053 "Miscellaneous Rough Carpentry"
- 2. Section 073113 "Architectural Laminated Shingles"

1.3 COORDINATION

- A. Coordinate sheet metal flashing and trim layout and seams with sizes and locations of penetrations to be flashed, and joints and seams in adjacent materials.
- B. Coordinate sheet metal flashing and trim installation with adjoining roofing and wall materials, joints, and seams to provide leak-proof, secure, and noncorrosive installation.

1.4 ACTION SUBMITTALS

- A. Product Data: For each type of product.

- 1. Include construction details, material descriptions, dimensions of individual components and profiles, and finishes for each manufactured product and accessory.

- B. Shop Drawings: For sheet metal flashing and trim.

- 1. Include identification of material, thickness, weight, and finish for each item and location in Project.

- C. Samples for Initial Selection: For each type of sheet metal and accessory indicated with factory-applied finishes.

- D. Samples for Verification: For each type of exposed finish.

1.5 INFORMATIONAL SUBMITTALS

- A. Qualification Data: For fabricator.
- B. Product Certificates: For each type of coping and roof edge flashing that is SPRI ES-1 tested.
- C. Sample Warranty: For special warranty.

1.6 CLOSEOUT SUBMITTALS

- A. Maintenance Data: For sheet metal flashing and trim, and its accessories, to include in maintenance manuals.

1.7 QUALITY ASSURANCE

- A. Fabricator Qualifications: Employs skilled workers who custom fabricate sheet metal flashing and trim similar to that required for this Project and whose products have a record of successful in-service performance.
 - 1. For roof edge flashings that are SPRI ES-1 tested, shop shall be listed as able to fabricate required details as tested and approved.

1.8 DELIVERY, STORAGE, AND HANDLING

- A. Do not store sheet metal flashing and trim materials in contact with other materials that might cause staining, denting, or other surface damage. Store sheet metal flashing and trim materials away from uncured concrete and masonry.
- B. Protect strippable protective covering on sheet metal flashing and trim from exposure to sunlight and high humidity, except to extent necessary for period of sheet metal flashing and trim installation.

1.9 WARRANTY

- A. Special Warranty on Finishes: Manufacturer agrees to repair finish or replace sheet metal flashing and trim that shows evidence of deterioration of factory-applied finishes within specified warranty period.
 - 1. Exposed Finish: Deterioration includes, but is not limited to, the following:
 - a. Color fading more than 5 Hunter units when tested according to ASTM D 2244.
 - b. Chalking in excess of a No. 8 rating when tested according to ASTM D 4214.
 - c. Cracking, checking, peeling, or failure of paint to adhere to bare metal.
 - 2. Finish Warranty Period: 30 years from date of Substantial Completion.

PART 2 - PRODUCTS

2.1 PERFORMANCE REQUIREMENTS

- A. General: Sheet metal flashing and trim assemblies shall withstand wind loads, structural movement, thermally induced movement, and exposure to weather without failure due to defective manufacture, fabrication, installation, or other defects in construction. Completed sheet metal flashing and trim shall not rattle, leak, or loosen, and shall remain watertight.
- B. Sheet Metal Standard for Flashing and Trim: Comply with NRCA's "The NRCA Roofing Manual" and SMACNA's "Architectural Sheet Metal Manual" requirements for dimensions and profiles shown unless more stringent requirements are indicated.
- C. SPRI Wind Design Standard: Manufacture and install roof edge flashings tested according to SPRI ES-1 and capable of resisting the design pressures.
- D. Thermal Movements: Allow for thermal movements from ambient and surface temperature changes to prevent buckling, opening of joints, overstressing of components, failure of joint sealants, failure of connections, and other detrimental effects. Base calculations on surface temperatures of materials due to both solar heat gain and nighttime-sky heat loss.

2.2 SHEET METALS

- A. General: Protect mechanical and other finishes on exposed surfaces from damage by applying strippable, temporary protective film before shipping.
- B. Galvalume Sheet: ASTM A792/A792M-97a, 50 ksi steel sheet, 55% Aluminum-Zinc Alloy Coating by the Hot-Dip Process, grade AZ55.
 - 1. Exposed Coil-Coated Finish:
 - a. Two-Coat Fluoropolymer: AAMA 620. Fluoropolymer finish containing not less than 70 percent PVDF resin by weight in color coat. Prepare, pretreat, and apply coating to exposed metal surfaces to comply with coating and resin manufacturers' written instructions.
 - 2. Color: As selected by Owner from manufacturer's full range.
 - 3. Concealed Finish: Pretreat with manufacturer's standard white or light-colored acrylic or polyester backer finish, consisting of prime coat and wash coat with minimum total dry film thickness of 0.5 mil.
 - 4. Component Thickness 24 gauge:
 - a. Gutters
 - b. Downspouts
 - c. Fascia
 - d. Drip Edge
- C. Aluminum Sheet: ASTM B 209, alloy as standard with manufacturer for finish required, with temper as required to suit forming operations and performance required; with smooth, flat surface.
 - 1. Exposed Coil-Coated Finish:

- a. Two-Coat Fluoropolymer: AAMA 620. Fluoropolymer finish containing not less than 70 percent PVDF resin by weight in color coat. Prepare, pretreat, and apply coating to exposed metal surfaces to comply with coating and resin manufacturers' written instructions.
 2. Color: As selected by Owner from manufacturer's full range.
 3. Concealed Finish: Pretreat with manufacturer's standard white or light-colored acrylic or polyester backer finish, consisting of prime coat and wash coat with minimum total dry film thickness of 0.5 mil.
 4. Component Thickness 0.040 inches:
 - a. Gutters
 - b. Downspouts
 - c. Fascia
 - d. Drip Edge
- D. Stainless-Steel Sheet: ASTM A 240/A 240M or ASTM A 666, Type 304, dead soft, fully annealed; with smooth, flat surface.
1. Component Thickness 24 gauge:
 - a. Umbrellas
- E. Lead Sheet: ASTM B749-03, heavy duty sheet lead, 4 lbs. /SF.
1. Vents Through Roof

2.3 UNDERLAYMENT MATERIALS

- A. Self-Adhering, High-Temperature Underlayment: Minimum 40 mils thick, consisting of a slip-resistant polyethylene- or polypropylene-film top surface laminated to a layer of butyl- or SBS-modified asphalt adhesive, with release-paper backing; specifically designed to withstand high metal temperatures beneath metal roofing. Provide primer according to written recommendations of underlayment manufacturer.
1. Thermal Stability: ASTM D 1970; stable after testing at 240 deg F or higher.
 2. Low-Temperature Flexibility: ASTM D 1970; passes after testing at minus 20 deg F or lower.
- B. Slip Sheet: Rosin-sized building paper, 3 lb/100 sq. ft. minimum.

2.4 MISCELLANEOUS MATERIALS

- A. General: Provide materials and types of fasteners, solder, protective coatings, sealants, and other miscellaneous items as required for complete sheet metal flashing and trim installation and as recommended by manufacturer of primary sheet metal unless otherwise indicated.
- B. Fasteners: Wood screws, annular threaded nails, self-tapping screws, self-locking rivets and bolts, and other suitable fasteners designed to withstand design loads and recommended by manufacturer of primary sheet metal.
1. General: Blind fasteners or self-drilling screws, gasketed, with hex-washer head.

- a. Exposed Fasteners: Heads matching color of sheet metal using plastic caps or factory-applied coating. Provide metal-backed EPDM or PVC sealing washers under heads of exposed fasteners bearing on weather side of metal.
 - b. Blind Fasteners: Low profile pancake head with length sufficient to penetrate metal substrates minimum 3 threads or wood substrates minimum 1-1/2".
2. Fasteners for Aluminum Sheet: Aluminum or Series 300 stainless steel.
 3. Fasteners for Stainless-Steel Sheet: Series 300 stainless steel.
 4. Fasteners for Zinc-Coated (Galvanized) Steel Sheet: Series 300 stainless steel or hot-dip galvanized steel according to ASTM A 153/A 153M or ASTM F 2329.
 5. Fasteners for Concrete and Masonry: 1/4" diameter metal based expansion anchor with stainless steel mandrel of length to penetrate substrate a minimum of 1-1/2".
 6. Washers: Shall be stainless steel with neoprene gasket backing. Shall be 9/16" diameter for use with #12 screws and 5/8" diameter for use with 1/4" diameter concrete and masonry anchors.
 7. Rivets: #44 Stainless steel rivets with stainless steel mandrel. Length of rivet to properly fasten particular sheet metal components. Rivets shall be factory painted to match adjacent sheet metal.
- C. Sealant Tape: Pressure-sensitive, 100 percent solids, polyisobutylene compound sealant tape with release-paper backing. Provide permanently elastic, nonsag, nontoxic, nonstaining tape 1/2 inch wide and 1/8 inch thick.
 - D. Elastomeric Sealant: ASTM C 920, elastomeric polyurethane polymer sealant; of type, grade, class, and use classifications required to seal joints in sheet metal flashing and trim and remain watertight.
 - E. Silicone Sealant: Shall be a one-component, non-sag, neutral cure, low-modulus, UV resistant, high performance silicone sealant. Shall meet ASTM C 920, Type S, Grade NS, Class 100, Use M, G, A or O. Color to match adjacent materials.
 - F. Butyl Sealant: ASTM C 1311, single-component, solvent-release butyl rubber sealant; polyisobutylene plasticized; heavy bodied for hooked-type expansion joints with limited movement.
 - G. Vinyl Retainer: 6-mil vinyl sheet for retaining insulation at expansion joints.

2.5 FABRICATION, GENERAL

- A. General: Custom fabricate sheet metal flashing and trim to comply with details shown and recommendations in cited sheet metal standard that apply to design, dimensions, geometry, metal thickness, and other characteristics of item required. Fabricate sheet metal flashing and trim in shop to greatest extent possible.
 1. Obtain field measurements for accurate fit before shop fabrication.
 2. Form sheet metal flashing and trim to fit substrates without excessive oil canning, buckling, and tool marks; true to line, levels, and slopes; and with exposed edges folded back to form hems.
 3. Conceal fasteners and expansion provisions where possible. Do not use exposed fasteners on faces exposed to view.
- B. Sealant Joints: Where movable, non-expansion-type joints are required, form metal to provide for proper installation of elastomeric sealant according to cited sheet metal standard.

- C. Fabricate cleats and attachment devices from same material as accessory being anchored or from compatible, noncorrosive metal. Cleats shall be 1 gauge/increment thicker than sheet metal used.
- D. Seams: Fabricate nonmoving seams with flat-lock seams. Form seams and seal with elastomeric sealant unless otherwise recommended by sealant manufacturer for intended use. Rivet joints where necessary for strength.

PART 3 - EXECUTION

3.1 INSTALLATION, GENERAL

- A. General: Anchor sheet metal flashing and trim and other components of the Work securely in place, with provisions for thermal and structural movement. Use fasteners, solder, protective coatings, separators, sealants, and other miscellaneous items as required to complete sheet metal flashing and trim system.
 - 1. Install sheet metal flashing and trim true to line, levels, and slopes. Provide uniform, neat seams with minimum exposure of solder, welds, and sealant.
 - 2. Install sheet metal flashing and trim to fit substrates resulting in watertight performance. Verify shapes and dimensions of surfaces to be covered before fabricating sheet metal.
 - 3. Install exposed sheet metal flashing and trim with limited oil canning, and free of buckling and tool marks.
 - 4. Torch cutting of sheet metal flashing and trim is not permitted.
 - 5. Prime all sheet metal surfaces (top and bottom) to receive bituminous materials. Allow primer to dry thoroughly before application of bituminous materials.
- B. Metal Protection: Where dissimilar metals contact each other, or where metal contacts pressure-treated wood or other corrosive substrates, protect against galvanic action or corrosion by painting contact surfaces with bituminous coating or by other permanent separation as recommended by sheet metal manufacturer or cited sheet metal standard.
- C. Expansion Provisions: Provide for thermal expansion of exposed flashing and trim. Space movement joints at maximum of 10 feet with no joints within 18 inches maximum or 24 inches minimum of corner or intersection.
- D. Fasteners: Use fastener sizes that penetrate wood blocking or sheathing not less than 1-1/2 inches for nails and not less than 1 inch for wood screws.
- E. Conceal fasteners and expansion provisions where possible in exposed work and locate to minimize possibility of leakage. Cover and seal fasteners and anchors as required for a tight installation.

3.2 UNDERLAYMENT INSTALLATION

- A. Self-Adhering Underlayment: Install self-adhering underlayment, wrinkle free. Prime substrate if recommended by underlayment manufacturer. Comply with temperature restrictions of underlayment manufacturer for installation; use primer for installing underlayment at low temperatures. Apply in shingle fashion to shed water, with end laps of not less than 6 inches staggered between courses. Overlap side edges not less than 3-1/2 inches. Roll laps and edges with roller. Cover underlayment within 14 days.

- B. Red Rosin Paper: Provide as slip sheet between sheet metal underlayment and copper.

3.3 ROOF-DRAINAGE SYSTEM INSTALLATION

- A. General: Install sheet metal roof-drainage items to produce complete roof-drainage system according to cited sheet metal standard unless otherwise indicated. Coordinate installation of roof perimeter flashing with installation of overflow roof-drainage system.
- B. Gutters and Downspouts: Gutters and Downspouts shall be sized and installed as indicated on Contract Drawings.

3.4 ROOF FLASHING INSTALLATION

- A. General: Install sheet metal flashing and trim to comply with performance requirements and cited sheet metal standard. Provide concealed fasteners where possible, and set units true to line, levels, and slopes. Install work with laps, joints, and seams that are permanently watertight and weather resistant.
- B. Roof Edge Flashing: Anchor to resist uplift and outward forces according to recommendations in cited sheet metal standard unless otherwise indicated. Interlock bottom edge of roof edge flashing with continuous cleat anchored to substrate.
- C. Pipe or Post Counterflashing: Install counterflashing umbrella with close-fitting collar with top edge flared for elastomeric sealant, extending minimum of 3 inches over base flashing. Install stainless-steel draw band and tighten.
- D. Roof-Penetration Flashing: Coordinate installation of roof-penetration flashing with installation of roofing and other items penetrating roof. Seal with sealant and clamp flashing to pipes that penetrate roof.

3.5 GUTTER AND DOWNSPOUT INSTALLATION

- A. Provide gutters in 10 feet sections.
- B. Provide gutter and downspout sizes as indicated in the Contract Drawings.
- C. For gutter profile, refer to SMACNA, figure 1-2, style D unless noted otherwise in the Contract Drawings. Back vertical leg of gutter shall be a minimum 1" higher than the front of the gutter.
- D. Join sections of gutter by lapping a minimum 4 inches; provide two continuous beads of butyl sealant between the lap and rivets 1 inch on center staggered.
- E. Gutter brackets shall be G90 Galvanized Steel, (gutters 7" or less) [1/8 inch thick x 1 inch wide] (gutters 8" or greater) [1/4 inch thick x 1-1/2" wide], clad in sheet metal to match the gutter color, provided 36 inches on center and secured to wood blocking with two low profile fasteners.
- F. Gutter straps shall be fabricated from flat stock sheet metal, minimum 1/16 inch x 1 inch, of the same material as the gutter; Spaced 36 inches on center, staggered from the gutter brackets.

Straps shall be fastened only to the front and back of the gutter. Notch hemmed edge of drip edge as necessary to install gutter straps.

- G. Gutter expansion joints shall be provided no more than 50 feet on center.
 - 1. Provide gutter end caps on both sides of the gutter expansion joint. End caps shall have minimum 1" flange, set in butyl sealant and riveted 1 inch on center. Cover tops of rivets with appropriate sealant.
 - 2. Sheet metal cap shall be provided over gutter end caps with hems on both sides to loose lock onto top flanges of end caps.
 - 3. Sheet metal cover plate shall be provided to match the profile of the gutter. Provide two strips of butyl tape or butyl sealant on both sides of cover plate. Secure to gutter on one side with rivets at 1 inch on center staggered.
 - 4. Refer to SMACNA Figure 1-7, Butt Type Gutter Expansion Joint.
- H. Provide downspout outlets at downspout locations. Outlets shall extend a minimum 4 inches below the bottom of the gutter, have minimum 1/2 inch flanges, set in butyl sealant and riveted to gutter at 1 inch on center. Provide sealant over rivets to seal mandrel holes; properly tool sealant to allow for proper drainage.
- I. Downspouts shall be provided in 10 feet long sections, spaced 1 inch off wall surface, with straps 6 inches from the top and bottom of the downspout and 5 feet on center.
- J. Where downspouts discharge to grade, provide concrete splash blocks or storm drainage connections.
- K. Where downspouts discharge onto a lower roof, provide stainless steel splash pan with baffles to slow the rate of water. Protection under splash pan shall be provided as required by the roof manufacturer.
- L. Ridge
 - 1. Fabricate ridge cap with continuous cleat as indicated in Contract Drawings in 10' sections.
 - 2. Set continuous cleat in two beads of sealant and secure with fasteners as indicated in the Contract Drawings.
 - 3. Strip in continuous cleat with self-adhering underlayment.
 - 4. Lock ridge cap onto continuous cleat; leave a 1/4" opening between continuous cleat sections, center aluminum tape over entire joint and strip in with self-adhering underlayment.
 - 5. Loose lock 1" hemmed edge of ridge cap onto continuous cleat and rivet through loose lock at 6" on center. At laps in ridge cap, rivet the underlying ridge cap only.
 - 6. Lap ridge cap minimum 4 inches and provide two strips of butyl sealant tape in laps.

3.6 CLEANING AND PROTECTION

- A. Clean exposed metal surfaces of substances that interfere with uniform oxidation and weathering.
- B. All sheet metal work shall be thoroughly cleaned of all asphalt, flux, scrapes and dust.
- C. Clean off excess sealants.

- D. Remove temporary protective coverings and strippable films as sheet metal flashing and trim are installed unless otherwise indicated in manufacturers written installation instructions.

END OF SECTION 076200

LANDER UNIVERSITY

BROOKSIDE BUILDING NO. 7 ROOF REPLACEMENT

DELIVERY ORDER PROJECT NUMBER: H21-PO16-09

WMBE PROJECT NUMBER: 2023-239

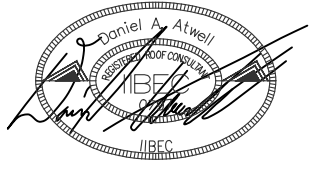

DESIGNED: DANIEL ATWELL

LANDER UNIVERSITY
 BROOKSIDE BUILDING NO. 7
 ROOF REPLACEMENT
 PROJECT NUMBER: H21-PO16-09
 LANDER UNIVERSITY
 GREENWOOD, SC



BUILDING ENVELOPE
CONSULTANTS, LLC

COLUMBIA AREA OFFICE

1611 CHAPIN ROAD
CHAPIN, SOUTH CAROLINA
EMAIL: CHRIS@WMBECONSULTANTS.COM
EMAIL: DANIEL@WMBECONSULTANTS.COM

CHARLESTON AREA OFFICE

226 N. LIVE OAK DRIVE
MONCK'S CORNER, SOUTH CAROLINA
EMAIL: JOE@WMBECONSULTANTS.COM
EMAIL: MAX@WMBECONSULTANTS.COM

THESE DRAWINGS ARE THE PROPERTY OF:

WM BUILDING ENVELOPE
CONSULTANTS, LLC

THE REPRODUCTION, COPYING OR OTHER
USE OF THESE DRAWINGS WITHOUT THEIR
WRITTEN CONSENT IS PROHIBITED AND
MAY BE SUBJECT TO LEGAL ACTION.

NORTH



PROJECT NUMBER: 2023-239

CONSTRUCTION DOCUMENTS

DATE: 10-12-2023

COVER PAGE

PAGE:

R-1.0

SHEET 1 OF 9

DRAWING LEGEND

- DS/SB | DOWNSPOUT TO SPLASH BLOCK
- GEJ | GUTTER EXPANSION JOINT
- VTR VENT THROUGH ROOF
- SHINGLE HATCH
- VENTING RIDGE CAP
- SLOPE ARROW
- ROOF EDGE AND OVERHANG

SITE LOCATION



BROOKSIDE STUDENT HOUSING

BROOKSIDE BUILDING NO. 7

CODE/INDUSTRY STANDARD REFERENCES

2018 IBC
2018 IEBC
2009 IECC
NRCA - LATEST EDITION
SMACNA - LATEST EDITION

DRAWING SHEETS

- R-1.0 COVER PAGE
- R-1.1 SPECIFICATIONS
- R-1.2 SPECIFICATIONS
- R-1.3 LANDER UNIVERSITY CAMPUS MAP
- R-2.1 BROOKSIDE BUILDING NO. 7 EXISTING ROOF PLAN
- R-2.2 BROOKSIDE BUILDING NO. 7 NEW ROOF PLAN
- D-1.1 DETAILS
- D-1.2 DETAILS
- D-1.3 DETAILS

ABBREVIATIONS

- MIN MINIMUM
- MAX MAXIMUM
- NRCA NATIONAL ROOFING CONTRACTORS ASSOCIATION
- O.C. ON CENTER
- SMACNA SHEET METAL AND AIR CONDITIONING CONTRACTORS NATIONAL ASSOCIATION

JOB CONTACTS

WMBE DANIEL ATWELL
803-422-7493
DANIEL@WMBECONSULTANTS.COM

LAMINATED ARCHITECTURAL SHINGLES:

PART 1:

1.00 - SUMMARY

- A. BASE BID:
- SCOPE OF WORK INCLUDES THE REPLACEMENT OF THE ASPHALT SHINGLE ROOF AND NEW GUTTER AND DOWNSPOUT SYSTEM SHALL BE INSTALLED.
 - ALL AREAS OF MISSING AND LOOSE SOFFIT SHALL BE REPLACED.
- B. SECTION INCLUDES:
- LAMINATED ARCHITECTURAL FIBERGLASS-REINFORCED ASPHALT SHINGLES.
 - STARTER SHINGLES.
 - SHINGLE UNDERLAYMENT SYSTEM.
 - HIP AND RIDGE PIECES
 - PRE-FABRICATED RIDGE VENTS.
 - FASTENERS.
 - METAL RAKE AND EAVE FLASHING AND TRIM.

1.01 - UNIT PRICES (SEE PROJECT MANUAL SPEC SECTION)

- A. UNIT PRICE IS A PRICE PER UNIT OF MEASUREMENT FOR MATERIALS, EQUIPMENT, OR SERVICES, OR A PORTION OF THE WORK.

1.02 - INFORMATIONAL SUBMITTALS

- A. PRODUCT LITERATURE: FOR COMPONENTS OF ROOFING SYSTEM, FROM ROOFING MANUFACTURER.
- B. CONTRACTOR'S WORKMANSHIP WARRANTY.

1.03 - REGULATORY REQUIREMENTS

- A. INSTALL ALL ROOFING PRODUCTS IN ACCORDANCE WITH ALL FEDERAL, STATE AND LOCAL BUILDING CODES.
- B. ALL WORK SHALL BE PERFORMED IN A MANNER CONSISTENT WITH CURRENT OSHA GUIDELINES.

1.04 - WARRANTY

- A. PROVIDE MANUFACTURER'S LIFETIME WARRANTY. MANUFACTURER'S LIFETIME WARRANTY SHALL INCLUDE ALL MATERIALS MANUFACTURED BY THE ROOF SYSTEM MANUFACTURER OR LABELED WITH THE MANUFACTURER'S NAME.
- B. PROVIDE ROOFING CONTRACTOR'S 2-YEAR WARRANTY FOR THE ROOF SYSTEM. THE 2-YEAR WARRANTY PERIOD WILL BE FROM THE SUBSTANTIAL COMPLETION DATE. THE ROOFING CONTRACTOR'S 2-YEAR WARRANTY SHALL BE SIGNED AND WILL INCLUDE ALL COMPONENTS OF THE ROOFING SYSTEM FOR THE WARRANTY PERIOD.

PART 2:

2.01 - QUALITY ASSURANCE

- A. CONTRACTOR SHALL BE APPROVED BY THE ROOFING SYSTEM MANUFACTURER TO INSTALL THE MANUFACTURER'S PRODUCT AND THAT IS ELIGIBLE TO RECEIVE THE SPECIFIED MANUFACTURER'S WARRANTY.
- B. A COPY OF THE LATEST MANUFACTURER'S PRODUCT DATA AND INSTALLATION GUIDE SHALL BE KEPT ON THE ROOF AT ALL TIMES DURING INSTALLATION.

PART 3: PRODUCTS

3.01 - LAMINATED ARCHITECTURAL SHINGLE ROOF DESCRIPTION

- A. LAMINATED ASPHALT SHINGLES: ASTM D3462, LAMINATED, MULTI-PLY CONSTRUCTION, GLASS-FIBER REINFORCED, MINERAL-GRANULE SURFACED, AND SELF-SEALING.
- B. MANUFACTURERS:
- GAF TIMBERLINE HD / HDZ
 - CERTAINTED LANDMARK PRO
 - OWENS CORNING DURATION

3.02 OTHER MATERIALS

- A. HIP AND RIDGE SHINGLES: USE THE MANUFACTURER'S FACTORY FABRICATED HIP AND RIDGE PIECES AS RECOMMENDED BY THE ROOF SYSTEM MANUFACTURER TO ADHERE TO THE SPECIFIED REQUIREMENTS.
- B. STARTER SHINGLES: USE THE MANUFACTURER'S FACTORY FABRICATED STARTER SHINGLES AS RECOMMENDED BY THE ROOF SYSTEM MANUFACTURER TO ADHERE TO THE SPECIFIED REQUIREMENTS.
- C. SHINGLE UNDERLAYMENT: NON-PERFORATED, SYNTHETIC ROOF UNDERLAYMENT MEETING ASTM D 226, TYPE II.
- D. RIDGE VENTS: MINIMUM 12-INCH-WIDE, INTERLOCKING, POLYPROPYLENE RIDGE VENT DESIGNED TO WORK WITH EAVE/SOFFIT INTAKE VENTILATION TO MAXIMIZE AIR FLOW THROUGH THE ROOF AND ATTIC STRUCTURE. SHALL PASS WIND-DRIVEN RAIN WITH 8.8 IN OF RAIN/HR. AT 110 MPH. THE VENTILATION SYSTEM SHALL ALLOW FOR A MINIMUM OF 1 SQ. FT. OF NET FREE AREA OF VENTILATION TO EVERY 150 FEET OF ATTIC SPACE
- E. FASTENERS: HOT-DIP GALVANIZED, COMPLYING WITH ASTM F1667, MINIMUM 12-GAUGE, 0.0808 INCH SHANK WITH 3/8 INCH DIAMETER HEAD. FASTENER SHALL BE OF SUFFICIENT LENGTH TO PENETRATE A MINIMUM OF 3/4 INCH INTO WOOD DECKING OR PENETRATE THROUGH WOOD DECKING A MINIMUM OF 1/8 INCH. ELECTROPLATED GALVANIZED FASTENERS ARE NOT PERMITTED FOR USE.
- F. ASPHALT ROOF CEMENT: ASTM D 4586, ASBESTOS FREE, COMPATIBLE WITH ROOFING SYSTEM AND ASSOCIATED COMPONENTS.
- G. SELF-ADHERING WATERPROOF UNDERLAYMENT: SELF-ADHERING, MODIFIED BITUMEN UNDERLAYMENT MEETING ASTM D 1970 AND TO BE INSTALLED CONTINUOUSLY AT ALL RAKES, EAVES, VALLEYS, HIPS, RIDGES AND AROUND ALL ROOF PENETRATIONS AND TERMINATIONS. SELF-ADHERING, MODIFIED BITUMEN UNDERLAYMENT IS ALSO REQUIRED TO BE INSTALLED CONTINUOUS ON SLOPES OF LESS THAN 4:12.
- H. PLUMBING VENT FLASHINGS: LEAD, MINIMUM 4 LB., SIZES TO MATCH PIPE SIZES, PAINTED TO MATCH ROOFING COLOR.

PART 4:

4.01 - INSTALLATION, GENERAL

- A. COMPLY WITH ROOFING SYSTEM MANUFACTURER'S WRITTEN INSTRUCTIONS.
- B. INSTALL ROOFING ACCORDING TO ROOFING SYSTEM MANUFACTURER'S WRITTEN INSTRUCTIONS AND APPLICABLE RECOMMENDATIONS IN ARMA/NRCA'S "QUALITY CONTROL GUIDELINES FOR THE APPLICATION OF POLYMER MODIFIED BITUMEN ROOFING".
- C. TEMPORARY PROTECTION TO BE PROVIDED IN ALL AREAS WHERE COMPLETE DETAIL IS NOT COMPLETED DAILY. ALL TEMPORARY PROTECTION TO BE WATERTIGHT.

4.02 - SUBSTRATE PREPARATION

- A. EXAMINE DECK AND OTHER SUBSTRATES FOR COMPLIANCE WITH REQUIREMENTS AFFECTING PERFORMANCE OF ROOFING SYSTEM..
- B. VERIFY THAT THE DECK IS DRY, STRUCTURALLY SOUND, CLEAN AND SMOOTH. DECK SHALL BE FREE OF ANY DEPRESSIONS, WAVES, AND PROJECTIONS. COVER ALL HOLES 1 INCH OR LESS IN DIAMETER, CRACKS OVER 1/2 IN IN WIDTH, LOOSE KNOTS AND EXCESSIVELY RESINOUS AREAS WITH MINIMUM 28 GAUGE GALVANIZED STEEL SHEET METAL. DECKING OR DECK BOARDS WITH HOLES GREATER THAN 1 INCH IN DIAMETER SHALL BE REPLACED.
- C. ENSURE SUBSTRATE HAS BEEN PROPERLY PREPARED PRIOR TO INSTALLATION OF ROOFING MATERIALS. DO NOT PROCEED WITH INSTALLATION UNTIL ALL CONDITIONS AFFECTING PROPER INSTALLATION HAVE BEEN CORRECTED.
- D. REMOVE EXISTING WALL AND TRIM MATERIALS AS NECESSARY TO INSTALL UNDERLAYMENT AND FLASHING MATERIALS. PROPERLY REINSTALL MATERIALS REMOVED UPON COMPLETION OF WORK.
- E. CLEAN AND REMOVE FROM SUBSTRATE, DUST, DEBRIS, MOISTURE, AND OTHER SUBSTANCES DETRIMENTAL TO ROOFING INSTALLATION.

4.03 UNDERLAYMENT AND EDGE METAL INSTALLATION

- A. ON SLOPES 4:12 OR GREATER, INSTALL SYNTHETIC ROOF UNDERLAYMENT OVER THE PREPARED SUBSTRATE IN SHINGLE FASHION LAPPED A MINIMUM OF 3 INCHES, IN ACCORDANCE WITH THE MANUFACTURER'S REQUIREMENTS AND IN ACCORDANCE WITH LOCAL BUILDING CODE REQUIREMENTS. SELF-ADHERING WATERPROOF UNDERLAYMENT SHALL BE A FULL 36 INCHES WIDE AND IS ALSO TO BE INSTALLED CONTINUOUSLY AT ALL RAKES, EAVES, VALLEYS, HIPS, RIDGES AND AROUND ALL ROOF PENETRATIONS AND TERMINATIONS. LAP ENDS A MINIMUM OF 6 INCHES AND SEAL. WHERE SELF-ADHERING WATERPROOF UNDERLAYMENT TERMINATES INTO A ROOF PENETRATION OR WALL, TURN UNDERLAYMENT UP THE WALL OR PENETRATION A MINIMUM OF 4 INCHES AND OUT ONTO THE ROOF A MINIMUM OF 12 INCHES UNLESS OTHERWISE RECOMMENDED BY THE ROOF SYSTEM MANUFACTURER.

- B. ON SLOPES LESS THAN 4:12, INSTALL SELF-ADHERING WATERPROOF UNDERLAYMENT OVER THE ENTIRE ROOF DECK. SELF-ADHERING WATERPROOF UNDERLAYMENT SHALL BE A FULL 36 INCHES WIDE. LAP ENDS A MINIMUM OF 6 INCHES AND SEAL. WHERE SELF-ADHERING WATERPROOF UNDERLAYMENT TERMINATES INTO A ROOF PENETRATION OR WALL, TURN UNDERLAYMENT UP THE WALL OR PENETRATION A MINIMUM OF 4 INCHES.
- C. METAL DRIP EDGE SHALL BE INSTALLED ON ALL ROOF EDGES. INSTALL DRIP EDGE ON EAVES FIRST WITH UNDERLAYMENT INSTALLED OVER THE DRIP EDGE. INSTALL DRIP EDGE ON RAKES AFTER UNDERLAYMENT IS INSTALLED, WITH THE DRIP EDGE FASTENED OVER THE UNDERLAYMENT. JOINTS IN DRIP EDGE SHALL BE LAPPED MINIMUM OF 3 INCHES AND SEALED WITH THE UPSLOPE PIECE LAPPED OVER THE DOWN SLOPE PIECE. METAL DRIP EDGE SHALL BE FASTENED A MINIMUM OF 6 INCHES ON CENTER, APPROXIMATELY 1-3/4 INCHES TO 2 INCHES FROM THE OUTSIDE EDGE OF THE DRIP EDGE.

4.04 LAMINATED ARCHITECTURAL INSTALLATION

- A. INSTALL ROOFING SYSTEM IN ACCORDANCE WITH ROOFING SYSTEM MANUFACTURER'S WRITTEN INSTRUCTIONS, WITH NRCA AND ARMA PRINTED RECOMMENDATIONS AND THE REQUIREMENTS IN THIS SECTION.
- B. COORDINATE INSTALLING ROOFING SYSTEM SO THAT THE COMPONENTS OF THE ROOFING SYSTEM SYSTEM ARE NOT EXPOSED OR SUBJECTED TO PRECIPITATION/INCLEMENT WEATHER OR LEFT UNCOVERED AT THE END OF THE WORKDAY.
- C. INSTALL STARTER COURSE AT ROOF EAVE AND ALONG RAKE WITH EDGE OF SHINGLES EXTENDING 1/4 IN OVER EDGE OF ROOF. SEALANT STRIP SHOULD BE CLOSEST TO ROOF EDGE.
- D. INSTALL FIRST AND SUCCESSIVE COURSES OF SHINGLES STEPPING DIAGONALLY UP AND ACROSS ROOF DECK WITH MANUFACTURER'S RECOMMENDED OFFSET AT EACH SUCCEEDING COURSE. MAINTAIN UNIFORM EXPOSURE OF SHINGLES AT EACH SUCCEEDING COURSE. USE OF A CHALK LINE EVERY OTHER /COURSE TO ENSURE STRAIGHT INSTALLATION.
- E. FASTEN SHINGLES TO DECK WITH A MINIMUM OF 6 FASTENERS PER SHINGLE. FASTEN SHINGLES IN ACCORDANCE WITH THE SHINGLE MANUFACTURER'S INSTALLATION INSTRUCTIONS AND SO THAT ALL LAYERS ARE SECURED.
- F. ALL FASTENERS SHALL PENETRATE AT LEAST 3/4 IN INTO THE WOOD DECK. WHERE THE DECK IS LESS THAN 3/4 IN THICK, THE FASTENER SHOULD BE LONG ENOUGH TO PENETRATE FULLY AND EXTEND THROUGH THE UNDERSIDE OF THE ROOF DECK. FASTENERS SHALL BE DRIVEN FLUSH WITH THE SHINGLE SURFACE AND NOT BE UNDER DRIVEN OR OVER DRIVEN.
- G. INSTALL SHINGLES AT VALLEYS, EAVES, RAKES, HIPS AND RIDGES IN ACCORDANCE WITH THE SHINGLE MANUFACTURER'S INSTALLATION INSTRUCTIONS.
- H. CLOSED-CUT AND OPEN VALLEYS: COMPLY WITH NRCA AND ARMA RECOMMENDATIONS.
- I. INSTALL MANUFACTURER'S PREFABRICATED RIDGE AND HIP CAPS IN STRICT ACCORDANCE WITH THE MANUFACTURERS PRINTED INSTRUCTIONS AND TO PROVIDE PROPER VENTING AND A WATERTIGHT DETAIL.
- J. INSTALL RIDGE VENTS IN STRICT ACCORDANCE WITH THE MANUFACTURERS PRINTED INSTRUCTIONS AND TO PROVIDE PROPER VENTING AND A WATERTIGHT DETAIL.

4.05 PROTECTION AND CLEANING

- A. PROTECT THE ROOFING SYSTEM FROM DAMAGE AND WEAR DURING THE COURSE OF CONSTRUCTION.
- B. CLEAN GROUNDS FREE OF ALL NAILS, SHEET METAL, SHINGLES AND OTHER SHINGLE ACCESSORIES EACH DAY.
- C. CLEAN ALL MARKS LEFT ON SURFACES FROM ROOFING MATERIALS FROM BUILDING AND SURROUNDING GROUNDS USING CLEANING AGENTS AND PROCEDURES RECOMMENDED BY MANUFACTURER OF AFFECTED CONSTRUCTION.

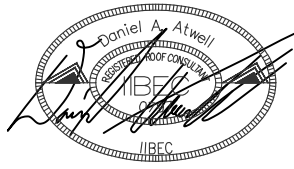

DESIGNED: DANIEL ATWELL

LANDER UNIVERSITY
BROOKSIDE BUILDING NO. 7
ROOF REPLACEMENT

PROJECT NUMBER: H21-PO16-09

LANDER UNIVERSITY
GREENWOOD, SC



COLUMBIA AREA OFFICE

1611 CHAPIN ROAD
CHAPIN, SOUTH CAROLINA
EMAIL: CHRIS@WMBECONSULTANTS.COM
EMAIL: DANIEL@WMBECONSULTANTS.COM

CHARLESTON AREA OFFICE

226 N. LIVE OAK DRIVE
MONCK'S CORNER, SOUTH CAROLINA
EMAIL: JOE@WMBECONSULTANTS.COM
EMAIL: MAX@WMBECONSULTANTS.COM

THESE DRAWINGS ARE THE PROPERTY OF:

WM BUILDING ENVELOPE
CONSULTANTS, LLC

THE REPRODUCTION, COPYING OR OTHER USE OF THESE DRAWINGS WITHOUT THEIR WRITTEN CONSENT IS PROHIBITED AND MAY BE SUBJECT TO LEGAL ACTION.

NORTH

PROJECT NUMBER: 2023-239

CONSTRUCTION DOCUMENTS

DATE: 10-12-2023

SPECIFICATIONS

PAGE:

R-1.1

SHEET 2 OF 9

SHEET METAL ROOF SPECIFICATION NOTES:

PART 1:

1.01 - PERFORMANCE REQUIREMENTS

- A. GENERAL: SHEET METAL FLASHING AND TRIM ASSEMBLIES SHALL WITHSTAND WIND LOADS, STRUCTURAL MOVEMENT, THERMALLY INDUCED MOVEMENT, AND EXPOSURE TO WEATHER WITHOUT FAILURE DUE TO DEFECTIVE MANUFACTURE, FABRICATION, INSTALLATION, OR OTHER DEFECTS IN CONSTRUCTION. COMPLETED SHEET METAL FLASHING AND TRIM SHALL NOT RATTLE, LEAK, OR LOOSEN, AND SHALL REMAIN WATERTIGHT.
- B. SHEET METAL STANDARD FOR FLASHING AND TRIM: COMPLY WITH NRCA'S "THE NRCA ROOFING MANUAL" AND SMACNA'S "ARCHITECTURAL SHEET METAL MANUAL" REQUIREMENTS FOR DIMENSIONS AND PROFILES SHOWN UNLESS MORE STRINGENT REQUIREMENTS ARE INDICATED.
- C. THERMAL MOVEMENTS: ALLOW FOR THERMAL MOVEMENTS FROM AMBIENT AND SURFACE TEMPERATURE CHANGES TO PREVENT BUCKLING, OPENING OF JOINTS, OVERSTRESSING OF COMPONENTS, FAILURE OF JOINT SEALANTS, FAILURE OF CONNECTIONS, AND OTHER DETRIMENTAL EFFECTS. BASE CALCULATIONS ON SURFACE TEMPERATURES OF MATERIALS DUE TO BOTH SOLAR HEAT GAIN AND NIGHTTIME-SKY HEAT LOSS.

1.02 - SHEET METALS (MATERIAL)

- A. GENERAL: PROTECT MECHANICAL AND OTHER FINISHES ON EXPOSED SURFACES FROM DAMAGE BY APPLYING STRIPPABLE, TEMPORARY PROTECTIVE FILM BEFORE SHIPPING.
- B. METAL EDGE FLASHING: PREFINISHED, MINIMUM .040 ALUMINUM OR 24 GAGE GALVANIZED STEEL, PRE-FORMED METAL EDGE DRIP FLASHING, COLOR SELECTED BY THE OWNER. MINIMUM 4 INCH FLANGE AND 2 INCH FACE.
- C. ALUMINUM SHEET: ASTM B 209, ALLOY AS STANDARD WITH MANUFACTURER FOR FINISH REQUIRED, WITH TEMPER AS REQUIRED TO SUIT FORMING OPERATIONS AND PERFORMANCE REQUIRED; WITH SMOOTH, FLAT SURFACE. MINIMUM THICKNESS 0.040 INCHES.
 - 1. EXPOSED COIL-COATED FINISH:
 - a. TWO-COAT FLUOROPOLYMER: AAMA 620. FLUOROPOLYMER FINISH CONTAINING NOT LESS THAN 70 PERCENT PVDF RESIN BY WEIGHT IN COLOR COAT. PREPARE, PRETREAT, AND APPLY COATING TO EXPOSED METAL SURFACES TO COMPLY WITH COATING AND RESIN MANUFACTURERS' WRITTEN INSTRUCTIONS.
 - 2. COLOR: AS SELECTED BY OWNER FROM MANUFACTURER'S FULL RANGE.
 - 3. CONCEALED FINISH: PRETREAT WITH MANUFACTURER'S STANDARD WHITE OR LIGHT-COLORED ACRYLIC OR POLYESTER BACKER FINISH, CONSISTING OF PRIME COAT AND WASH COAT WITH MINIMUM TOTAL DRY FILM THICKNESS OF 0.5 MIL.
- D. METALLIC-COATED STEEL SHEET: PROVIDE ALUMINUM-ZINC ALLOY-COATED STEEL SHEET ACCORDING TO ASTM A 792/A 792M, CLASS AZ50 COATING DESIGNATION, PRE-PAINTED BY COIL-COATING PROCESS TO COMPLY WITH ASTM A 755/A 755M.
 - 1. SURFACE: SMOOTH, FLAT AND WITH MANUFACTURER'S STANDARD CLEAR ACRYLIC COATING ON BOTH SIDES.
 - 2. EXPOSED COIL-COATED FINISH:
 - a. TWO-COAT FLUOROPOLYMER: AAMA 621. FLUOROPOLYMER FINISH CONTAINING NOT LESS THAN 70 PERCENT PVDF RESIN BY WEIGHT IN COLOR COAT. PREPARE, PRETREAT, AND APPLY COATING TO EXPOSED METAL SURFACES TO COMPLY WITH COATING AND RESIN MANUFACTURERS' WRITTEN INSTRUCTIONS.
 - 3. COLOR: AS SELECTED BY OWNER FROM MANUFACTURER'S FULL RANGE STANDARD COLOR CHART.
 - 4. CONCEALED FINISH: PRETREAT WITH MANUFACTURER'S STANDARD WHITE OR LIGHT-COLORED ACRYLIC OR POLYESTER BACKER FINISH, CONSISTING OF PRIME COAT AND WASH COAT WITH MINIMUM TOTAL DRY FILM THICKNESS OF 0.5 MIL.
- E. STAINLESS-STEEL SHEET: ASTM A 240/A 240M OR ASTM A 666, TYPE 304, DEAD SOFT, FULLY ANNEALED; WITH SMOOTH, FLAT SURFACE. MINIMUM THICKNESS 24 GAUGE.

1.2 UNDERLAYMENT MATERIALS

- A. SELF-ADHERING, HIGH-TEMPERATURE SHEET: MINIMUM 40 MILS THICK, CONSISTING OF A SLIP-RESISTANT POLYETHYLENE- OR POLYPROPYLENE-FILM TOP SURFACE LAMINATED TO A LAYER OF BUTYL- OR SBS-MODIFIED ASPHALT ADHESIVE, WITH RELEASE-PAPER BACKING; SPECIFICALLY DESIGNED TO WITHSTAND HIGH METAL TEMPERATURES BENEATH METAL ROOFING. PROVIDE PRIMER ACCORDING TO WRITTEN RECOMMENDATIONS OF UNDERLAYMENT MANUFACTURER.
 - 1. THERMAL STABILITY: ASTM D 1970; STABLE AFTER TESTING AT 240 DEG F OR HIGHER.
 - 2. LOW-TEMPERATURE FLEXIBILITY: ASTM D 1970; PASSES AFTER TESTING AT MINUS 20 DEG F OR LOWER.

1.03 - MISCELLANEOUS MATERIALS

- A. GENERAL: PROVIDE MATERIALS AND TYPES OF FASTENERS, SOLDER, PROTECTIVE COATINGS, SEALANTS, AND OTHER MISCELLANEOUS ITEMS AS REQUIRED FOR COMPLETE SHEET METAL FLASHING AND TRIM INSTALLATION AND AS RECOMMENDED BY MANUFACTURER OF PRIMARY SHEET METAL UNLESS OTHERWISE INDICATED.

1.04 - FABRICATION, GENERAL

- A. GENERAL: CUSTOM FABRICATE SHEET METAL FLASHING AND TRIM TO COMPLY WITH DETAILS SHOWN AND RECOMMENDATIONS IN CITED SHEET METAL STANDARD THAT APPLY TO DESIGN, DIMENSIONS, GEOMETRY, METAL THICKNESS, AND OTHER CHARACTERISTICS OF ITEM REQUIRED. FABRICATE SHEET METAL FLASHING AND TRIM IN SHOP TO GREATEST EXTENT POSSIBLE.
 - 1. OBTAIN FIELD MEASUREMENTS FOR ACCURATE FIT BEFORE SHOP FABRICATION.
 - 2. FORM SHEET METAL FLASHING AND TRIM TO FIT SUBSTRATES WITHOUT EXCESSIVE OIL CANNING, BUCKLING, AND TOOL MARKS; TRUE TO LINE, LEVELS, AND SLOPES; AND WITH EXPOSED EDGES FOLDED BACK TO FORM HEMS.
 - 3. CONCEAL FASTENERS AND EXPANSION PROVISIONS WHERE POSSIBLE. DO NOT USE EXPOSED FASTENERS ON FACES EXPOSED TO VIEW.
- B. SEAMS: FABRICATE NONMOVING SEAMS WITH FLAT-LOCK SEAMS. FORM SEAMS AND SEAL WITH ELASTOMERIC SEALANT UNLESS OTHERWISE RECOMMENDED BY SEALANT MANUFACTURER FOR INTENDED USE. RIVET JOINTS WHERE NECESSARY FOR STRENGTH.
- C. COUNTERFLASHING: INSTALL COUNTERFLASHING UMBRELLA WITH CLOSE-FITTING COLLAR WITH TOP EDGE FLARED FOR ELASTOMERIC SEALANT
- D. ROOF-PENETRATION FLASHING: COORDINATE INSTALLATION OF ROOF-PENETRATION FLASHING WITH INSTALLATION OF ROOFING AND OTHER ITEMS PENETRATING ROOF. SEAL WITH SEALANT AND CLAMP FLASHING TO PIPES THAT PENETRATE ROOF.

1.05 - CLEANING AND PROTECTION

- A. CLEAN EXPOSED METAL SURFACES OF SUBSTANCES THAT INTERFERE WITH UNIFORM OXIDATION AND WEATHERING.
- B. CLEAN OFF EXCESS SEALANTS.
- C. REMOVE TEMPORARY PROTECTIVE COVERINGS AND STRIPPABLE FILMS AS SHEET METAL FLASHING AND TRIM ARE INSTALLED UNLESS OTHERWISE INDICATED IN MANUFACTURERS WRITTEN INSTALLATION INSTRUCTIONS.

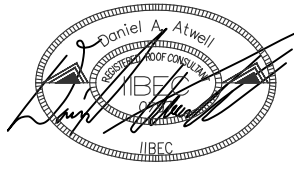

DESIGNED: DANIEL ATWELL

LANDER UNIVERSITY
BROOKSIDE BUILDING NO. 7
ROOF REPLACEMENT

PROJECT NUMBER: H21-PO16-09
LANDER UNIVERSITY
GREENWOOD, SC



BUILDING ENVELOPE
CONSULTANTS, LLC

COLUMBIA AREA OFFICE

1611 CHAPIN ROAD
CHAPIN, SOUTH CAROLINA
EMAIL: CHRIS@WMBECONSULTANTS.COM
EMAIL: DANIEL@WMBECONSULTANTS.COM

CHARLESTON AREA OFFICE

226 N. LIVE OAK DRIVE
MONCK'S CORNER, SOUTH CAROLINA
EMAIL: JOE@WMBECONSULTANTS.COM
EMAIL: MAX@WMBECONSULTANTS.COM

THESE DRAWINGS ARE THE PROPERTY OF:

WM BUILDING ENVELOPE
CONSULTANTS, LLC

THE REPRODUCTION, COPYING OR OTHER
USE OF THESE DRAWINGS WITHOUT THEIR
WRITTEN CONSENT IS PROHIBITED AND
MAY BE SUBJECT TO LEGAL ACTION.

NORTH

PROJECT NUMBER: 2023-239

CONSTRUCTION DOCUMENTS

DATE: 10-12-2023

SPECIFICATIONS

PAGE:

R-1.2

SHEET 3 OF 9

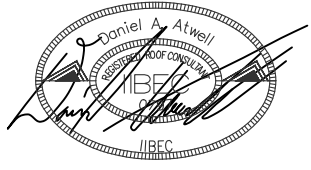

DESIGNED: DANIEL ATWELL

LANDER UNIVERSITY CAMPUS MAP - 320 STANLEY AVENUE, GREENWOOD, SC

- ADMINISTRATIVE BUILDINGS**
- Art Studio..... LB
 - Barratt Hall..... BH
 - Carnell Learning Center..... LC
 - Grier Student Center..... GC
 - Jackson Library..... JL
 - Josephine B. Abney Cultural Center..... CC
 - Laura Lander Hall..... LL
 - Science Building..... SC
- ATHLETICS FACILITIES**
- Athletics Center/Home Arena..... AC
 - Chandler PEES Center..... PS
 - Jeff May Complex..... JMC
 - Sproles Recreation Center..... RC

- CAMPUS SERVICES**
- Academic Success Center..... GE
 - Admissions Office..... A
 - Alumni Affairs & Lander Foundation..... AF
 - Facilities Operation..... FO
 - Human Resources..... HR
 - IT Services..... IL
 - Student Health Services..... CW
 - Student Support Services..... WL
 - University Police..... UE
- OUTDOOR FACILITIES**
- Amphitheatre..... DI
 - Moran Assembly Plaza..... AP

- ★ A - Admissions Office
- ★ H - Housing & Residence Life Office

- STUDENT HOUSING**
- Bearcat Village..... BV(A-M)
 - Brookside..... B(1-7)
 - Centennial Hall..... CH
 - Chipley Hall..... CP
 - Lide..... L(1-5)
 - McGhee Court..... MC(1-8)
 - New Residence Hall..... NRH
 - Thomason..... T(A-S)
 - University Place..... UP(1-6)
 - Williamston..... W(1-8)
- PARKING AREAS**
- Faculty, Staff, Commuter..... FSC
 - Visitors..... VP

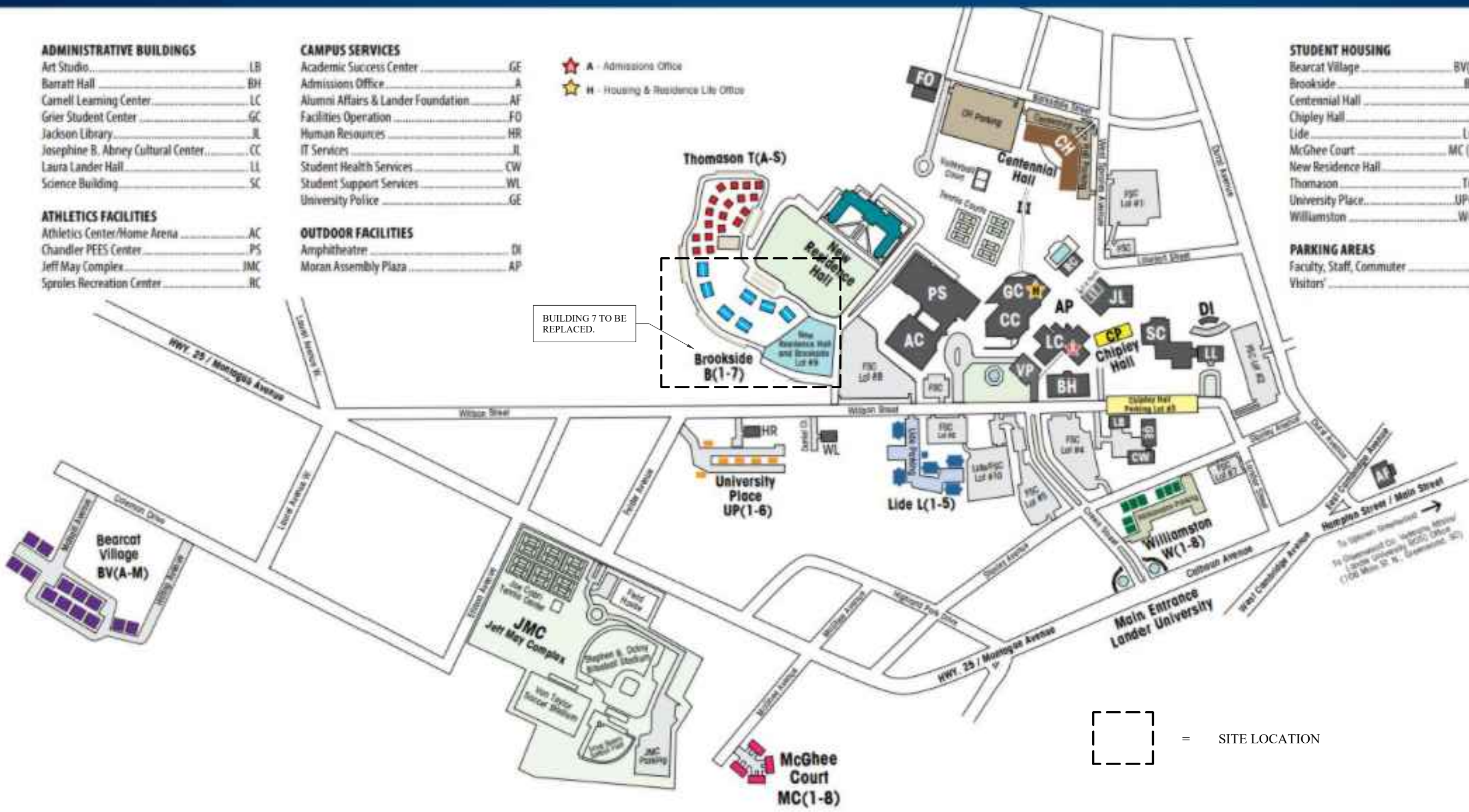

= SITE LOCATION

LANDER UNIVERSITY
BROOKSIDE BUILDING NO. 7
ROOF REPLACEMENT

PROJECT NUMBER: H21-PO16-09

LANDER UNIVERSITY
GREENWOOD, SC



BUILDING ENVELOPE CONSULTANTS, LLC

COLUMBIA AREA OFFICE

1611 CHAPIN ROAD
CHAPIN, SOUTH CAROLINA
EMAIL: CHRIS@WMBECONSULTANTS.COM
EMAIL: DANIEL@WMBECONSULTANTS.COM

CHARLESTON AREA OFFICE

226 N. LIVE OAK DRIVE
MONCK'S CORNER, SOUTH CAROLINA
EMAIL: JOE@WMBECONSULTANTS.COM
EMAIL: MAX@WMBECONSULTANTS.COM

THESE DRAWINGS ARE THE PROPERTY OF:
WM BUILDING ENVELOPE CONSULTANTS, LLC

THE REPRODUCTION, COPYING OR OTHER USE OF THESE DRAWINGS WITHOUT THEIR WRITTEN CONSENT IS PROHIBITED AND MAY BE SUBJECT TO LEGAL ACTION.

NORTH



PROJECT NUMBER: 2023-239

CONSTRUCTION DOCUMENTS

DATE: 10-12-2023

CAMPUS MAP

PAGE:

R-1.3

NOTE:
 1. CLEAN ALL ROOF AREAS OF ALL DEBRIS. ALL TREES TO BE REMOVED / TRIMMED AWAY FROM ROOF AREA.

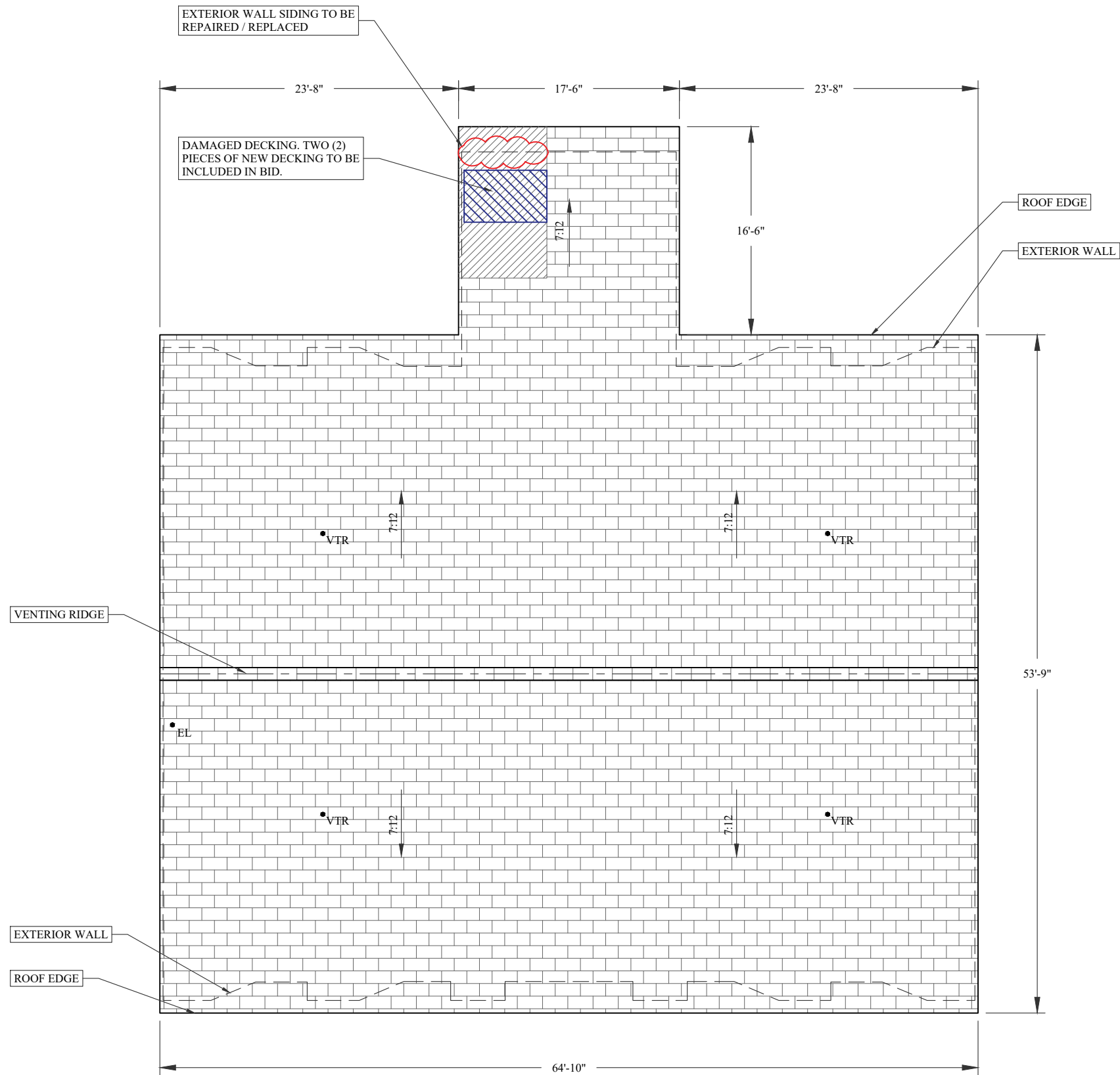

B BUILDING "7"
 1/16" = 1'-0"

**BROOKSIDE BUILDING NO. 7
 EXISTING ROOF PLAN**

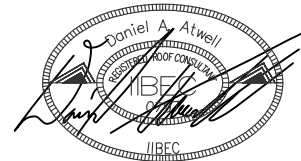

DESIGNED: DANIEL ATWELL

**LANDER UNIVERSITY
 BROOKSIDE BUILDING NO. 7
 ROOF REPLACEMENT**
PROJECT NUMBER: H21-PO16-09
**LANDER UNIVERSITY
 GREENWOOD, SC**

WM
 BUILDING ENVELOPE
 CONSULTANTS, LLC
 COLUMBIA AREA OFFICE
 1611 CHAPIN ROAD
 CHAPIN, SOUTH CAROLINA
 EMAIL: CHRIS@WMBECONSULTANTS.COM
 EMAIL: DANIEL@WMBECONSULTANTS.COM
 CHARLESTON AREA OFFICE
 226 N. LIVE OAK DRIVE
 MONCK'S CORNER, SOUTH CAROLINA
 EMAIL: JOE@WMBECONSULTANTS.COM
 EMAIL: MAX@WMBECONSULTANTS.COM

THESE DRAWINGS ARE THE PROPERTY OF:
 WM BUILDING ENVELOPE
 CONSULTANTS, LLC
 THE REPRODUCTION, COPYING OR OTHER
 USE OF THESE DRAWINGS WITHOUT THEIR
 WRITTEN CONSENT IS PROHIBITED AND
 MAY BE SUBJECT TO LEGAL ACTION.



PROJECT NUMBER: 2023-239
 CONSTRUCTION DOCUMENTS
 DATE: 10-12-2023
**BROOKSIDE BUILDING NO. 7
 EXISTING ROOF PLAN**
PAGE:
R-2.1
 SHEET 5 OF 9

NOTE:

1. CONTRACTOR TO FIELD VERIFY ALL DIMENSIONS, PENETRATIONS, AND EXISTING ROOF CORE SUMMARY.

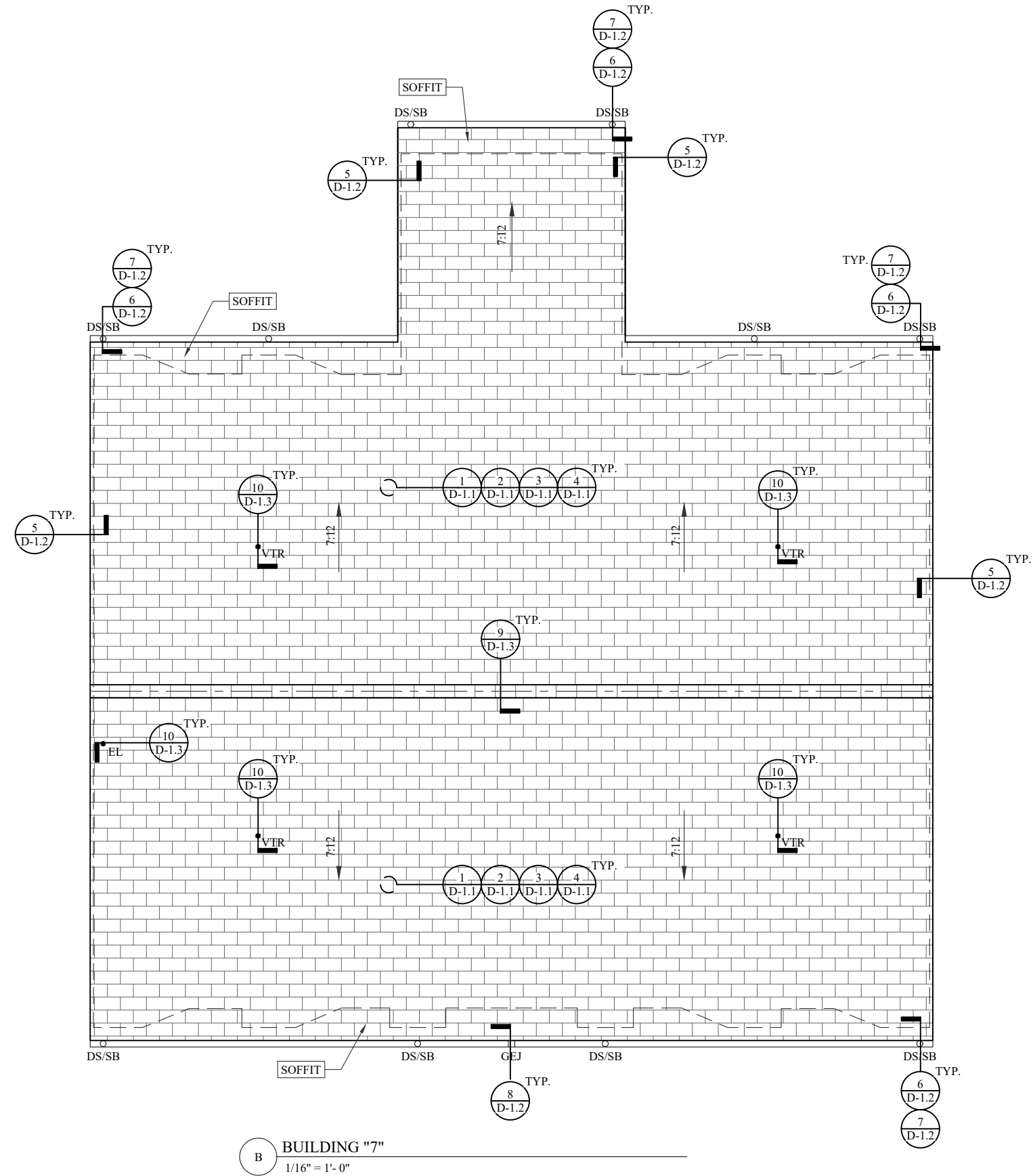

B BUILDING "7"
1/16" = 1'-0"

**BROOKSIDE BUILDING NO. 7
NEW ROOF PLAN**

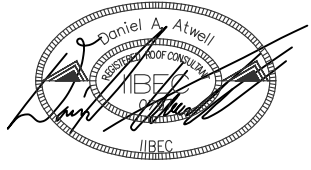

DESIGNED: DANIEL ATWELL

**LANDER UNIVERSITY
BROOKSIDE BUILDING NO. 7
ROOF REPLACEMENT**

PROJECT NUMBER: H21-PO16-09

**LANDER UNIVERSITY
GREENWOOD, SC**



**BUILDING ENVELOPE
CONSULTANTS, LLC**

COLUMBIA AREA OFFICE

1611 CHAPIN ROAD
CHAPIN, SOUTH CAROLINA
EMAIL: CHRIS@WMBECONSULTANTS.COM
EMAIL: DANIEL@WMBECONSULTANTS.COM

CHARLESTON AREA OFFICE

226 N. LIVE OAK DRIVE
MONCK'S CORNER, SOUTH CAROLINA
EMAIL: JOE@WMBECONSULTANTS.COM
EMAIL: MAX@WMBECONSULTANTS.COM

THESE DRAWINGS ARE THE PROPERTY OF:
WM BUILDING ENVELOPE
CONSULTANTS, LLC

THE REPRODUCTION, COPYING OR OTHER
USE OF THESE DRAWINGS WITHOUT THEIR
WRITTEN CONSENT IS PROHIBITED AND
MAY BE SUBJECT TO LEGAL ACTION.



PROJECT NUMBER: 2023-239

CONSTRUCTION DOCUMENTS

DATE: 10-12-2023

**BROOKSIDE BUILDING
NO. 7 NEW ROOF PLAN**

PAGE:

R-2.2

NOTE:

1. CONTRACTOR TO FIELD VERIFY ALL EXISTING CONDITIONS AND MATCH EXISTING CONDITIONS DURING RE-INSTALLATION OF FRAMING / SUBSTRATE / STEEP SLOPE ROOF SYSTEM.

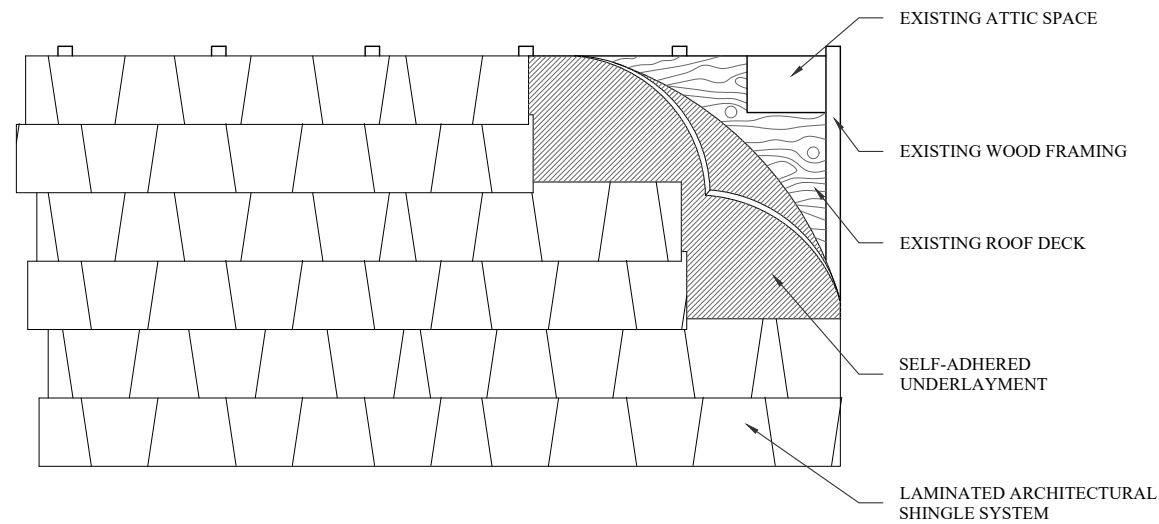

**ARCHITECTURAL LAMINATE
SHINGLE ASSEMBLY
DETAIL 1/D-1.1**

NOTES:

1. 3/4" MINIMUM PENETRATION INTO WOOD DECK.
2. ALL REQUIREMENTS PER NRCA STEEP SLOPE ROOFING MANUAL IS REQUIRED.

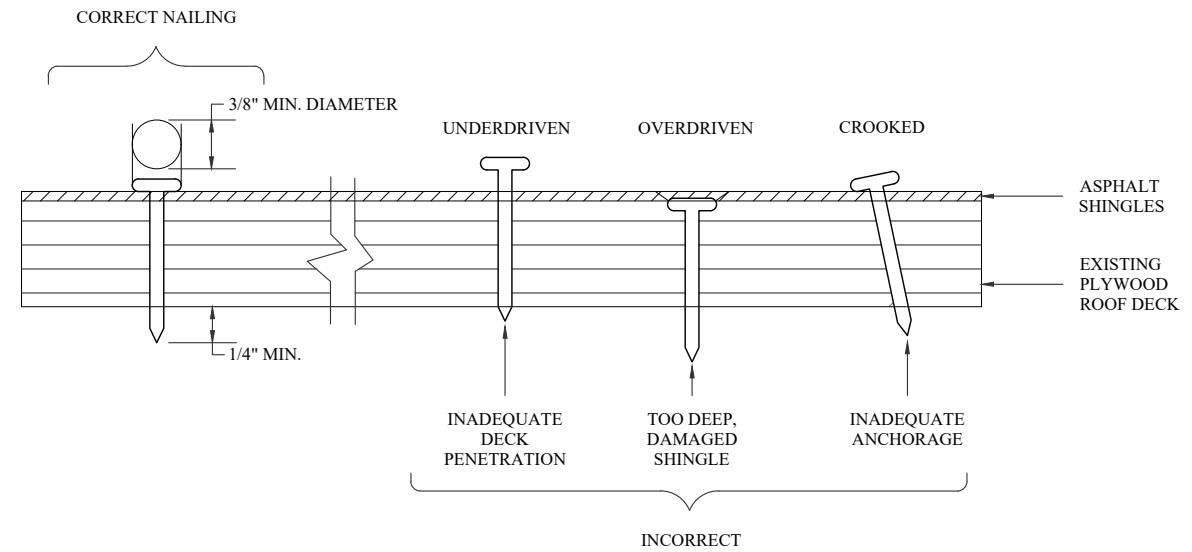

**SHINGLE FASTENING STANDARD
DETAIL 2/D-1.1**

NOTES:

1. SIX (6) FASTENERS ARE REQUIRED TO BE INSTALLED PER SHINGLE INSTALLATION.
2. FASTENING PATTERN LAYOUT MAY VARY BASED ON MANUFACTURER REQUIREMENTS.

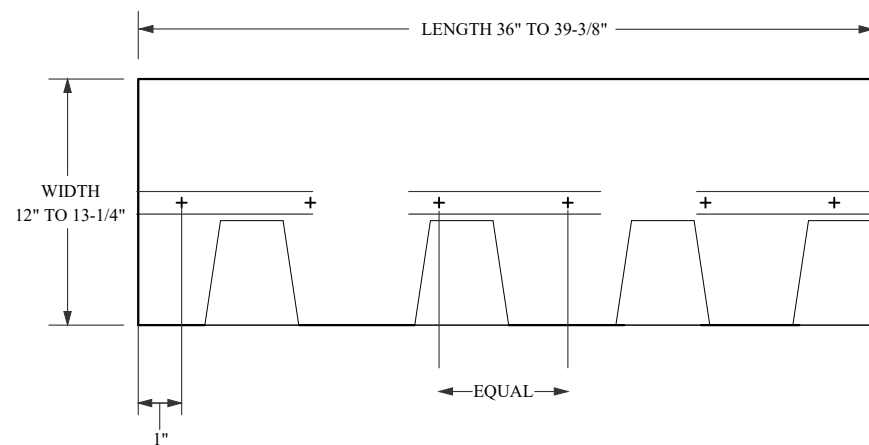

**FASTENER LAYOUT
(GENERAL)
DETAIL 3/D-1.1**

NOTES:

1. DIMENSION OF STAGGER PER MANUFACTURER REQUIREMENTS.
2. UNDERLAYMENT SYSTEM NOT SHOWN FOR CLARITY.

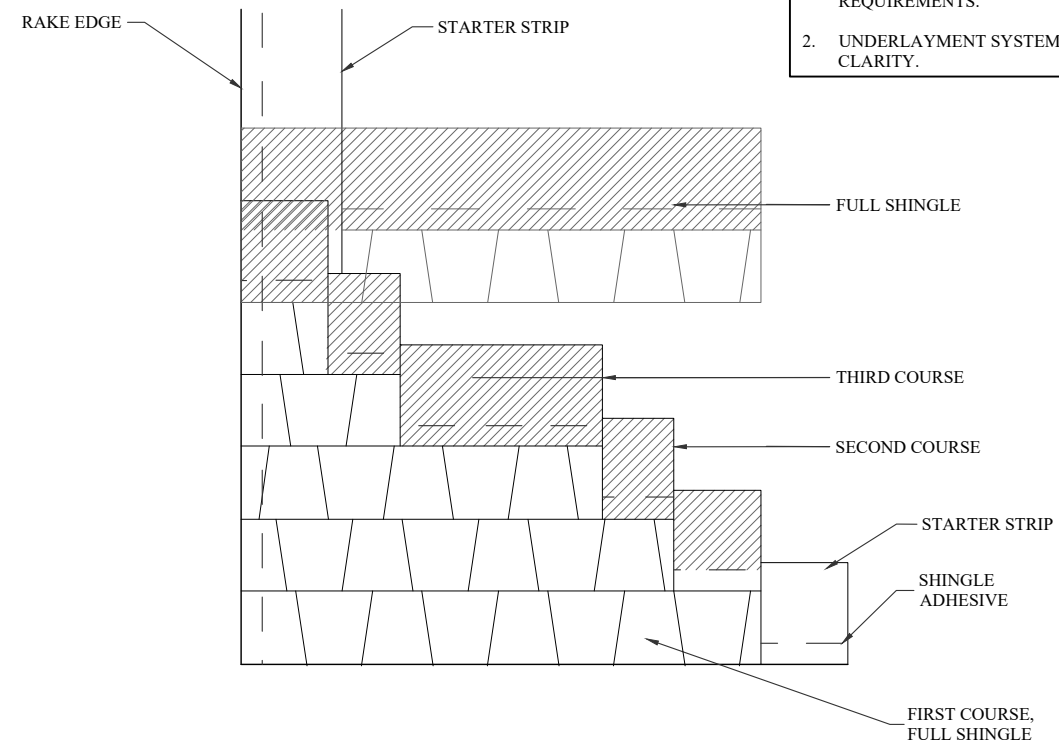

**SHINGLE INSTALLATION
DETAIL 4/D-1.1**

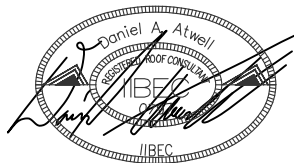

DESIGNED: DANIEL ATWELL

**LANDER UNIVERSITY
BROOKSIDE BUILDING NO. 7
ROOF REPLACEMENT**

PROJECT NUMBER: H21-PO16-09

**LANDER UNIVERSITY
GREENWOOD, SC**



BUILDING ENVELOPE
CONSULTANTS, LLC
COLUMBIA AREA OFFICE

1611 CHAPIN ROAD
CHAPIN, SOUTH CAROLINA
EMAIL: CHRIS@WMBECONSULTANTS.COM
EMAIL: DANIEL@WMBECONSULTANTS.COM

CHARLESTON AREA OFFICE

 226 N. LIVE OAK DRIVE
MONCK'S CORNER, SOUTH CAROLINA
EMAIL: JOE@WMBECONSULTANTS.COM
EMAIL: MAX@WMBECONSULTANTS.COM

THESE DRAWINGS ARE THE PROPERTY OF:

 WM BUILDING ENVELOPE
CONSULTANTS, LLC

THE REPRODUCTION, COPYING OR OTHER
USE OF THESE DRAWINGS WITHOUT THEIR
WRITTEN CONSENT IS PROHIBITED AND
MAY BE SUBJECT TO LEGAL ACTION.

PROJECT NUMBER: 2023-239

CONSTRUCTION DOCUMENTS

DATE: 10-12-2023

DETAILS

PAGE:

D-1.1

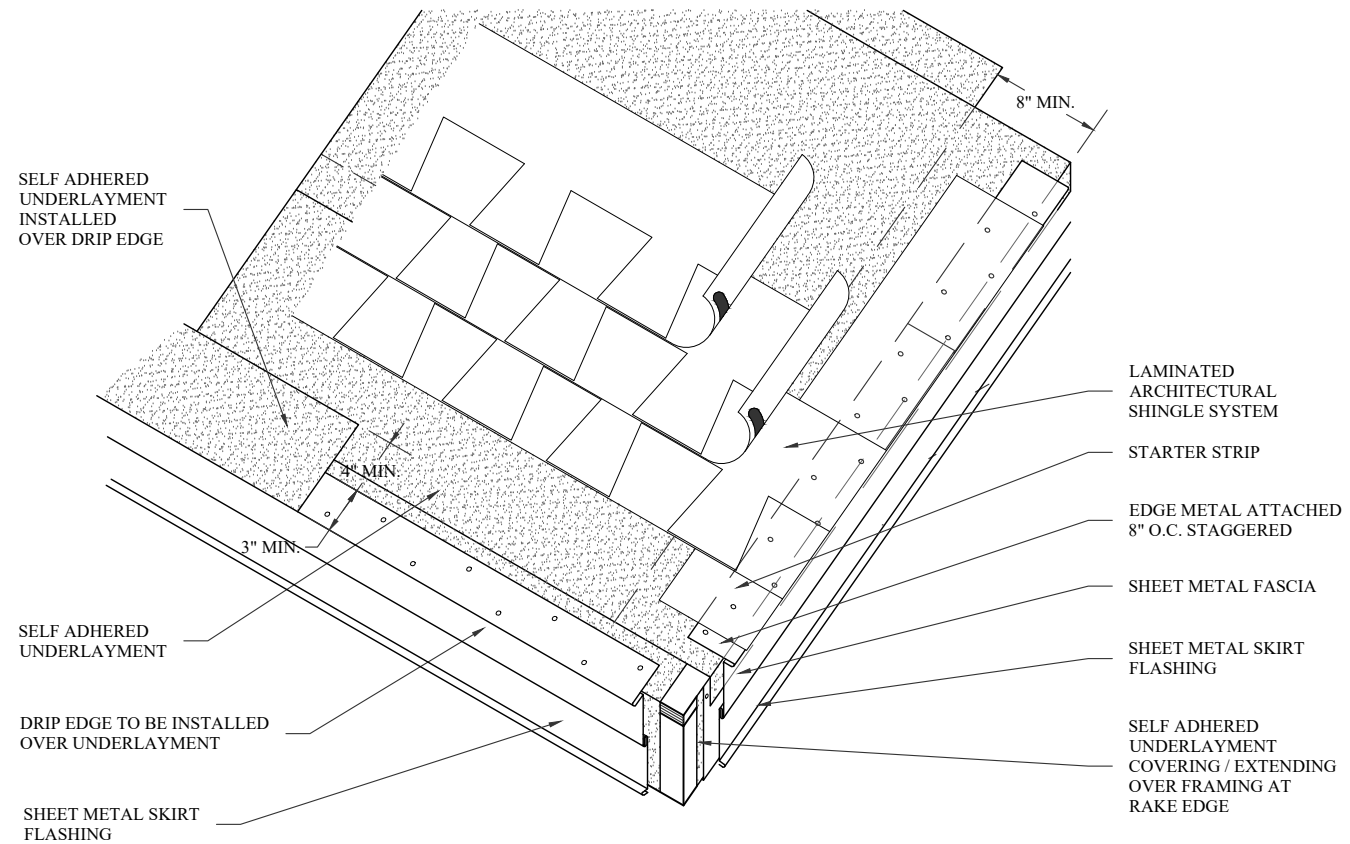

**RAKE EDGE (TWO PIECE
EDGE METAL)
DETAIL 5/D-1.2**

- NOTES:**
1. MANUFACTURERS STARTER SHINGLE IS REQUIRED.
 2. "SEAMLESS" STYLE GUTTER SYSTEM IS REQUIRED

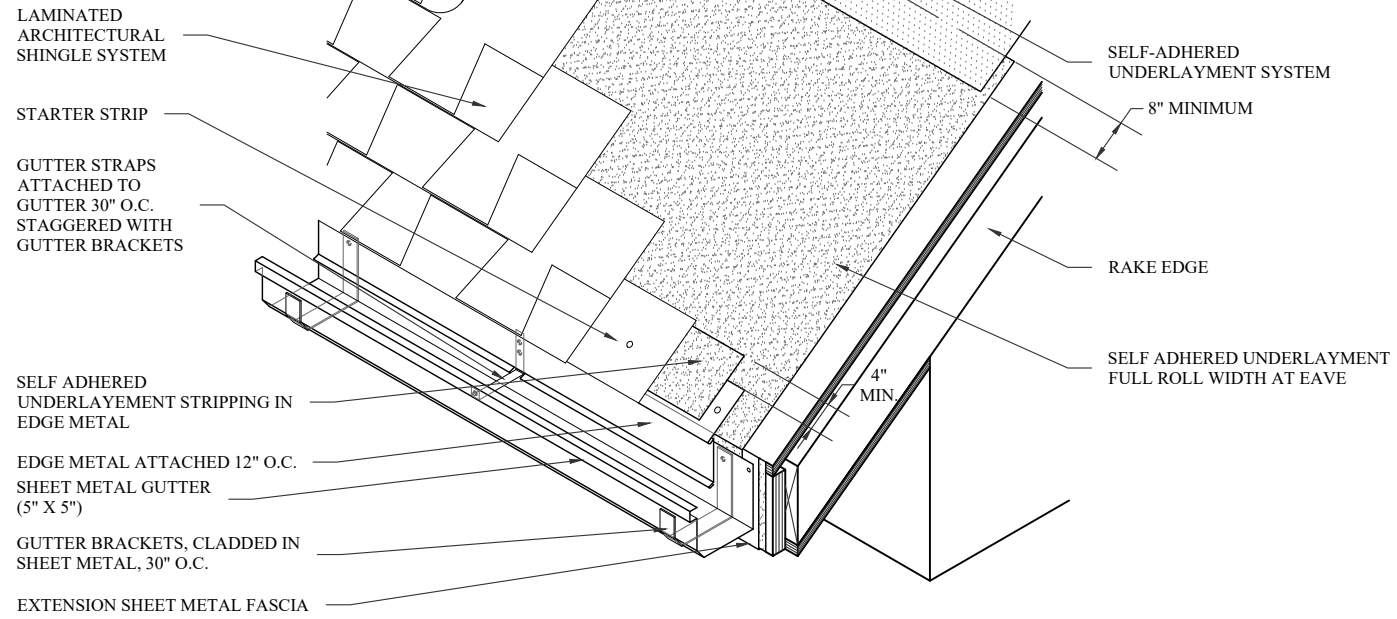

**ROOF EDGE WITH GUTTER
DETAIL 6/D-1.2**

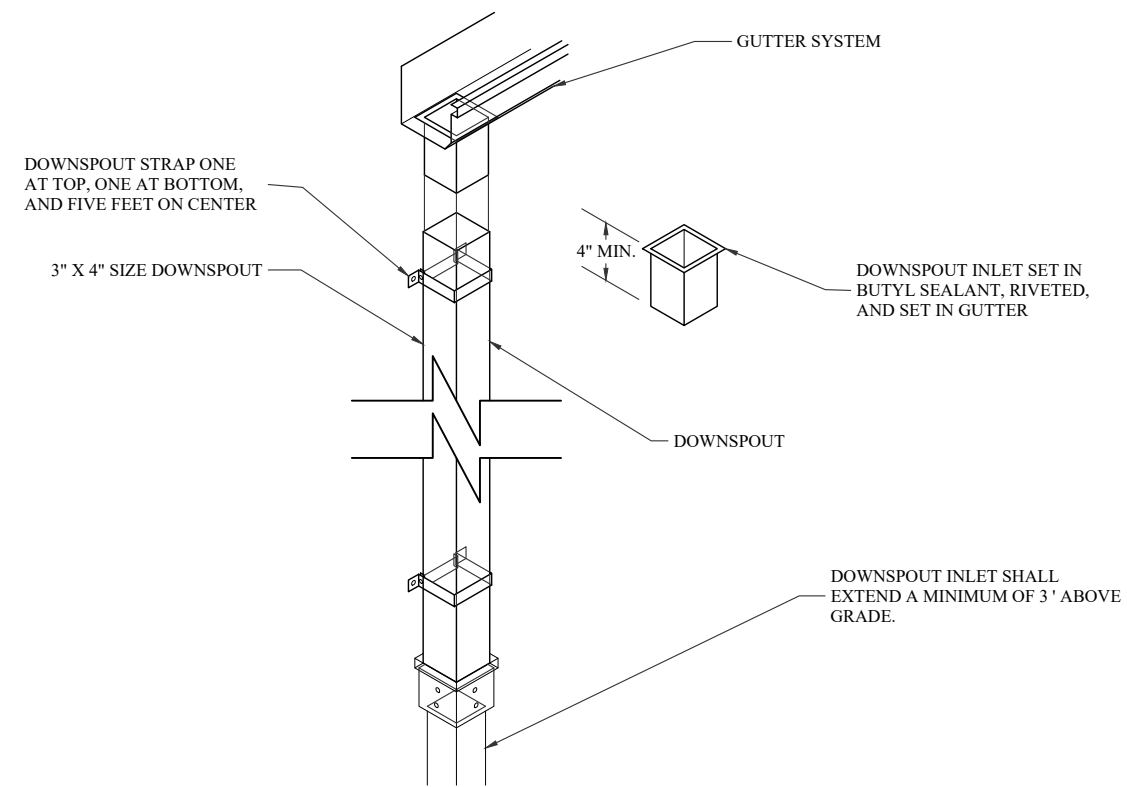

**DOWNSPOUT
DETAIL 7/D-1.2**

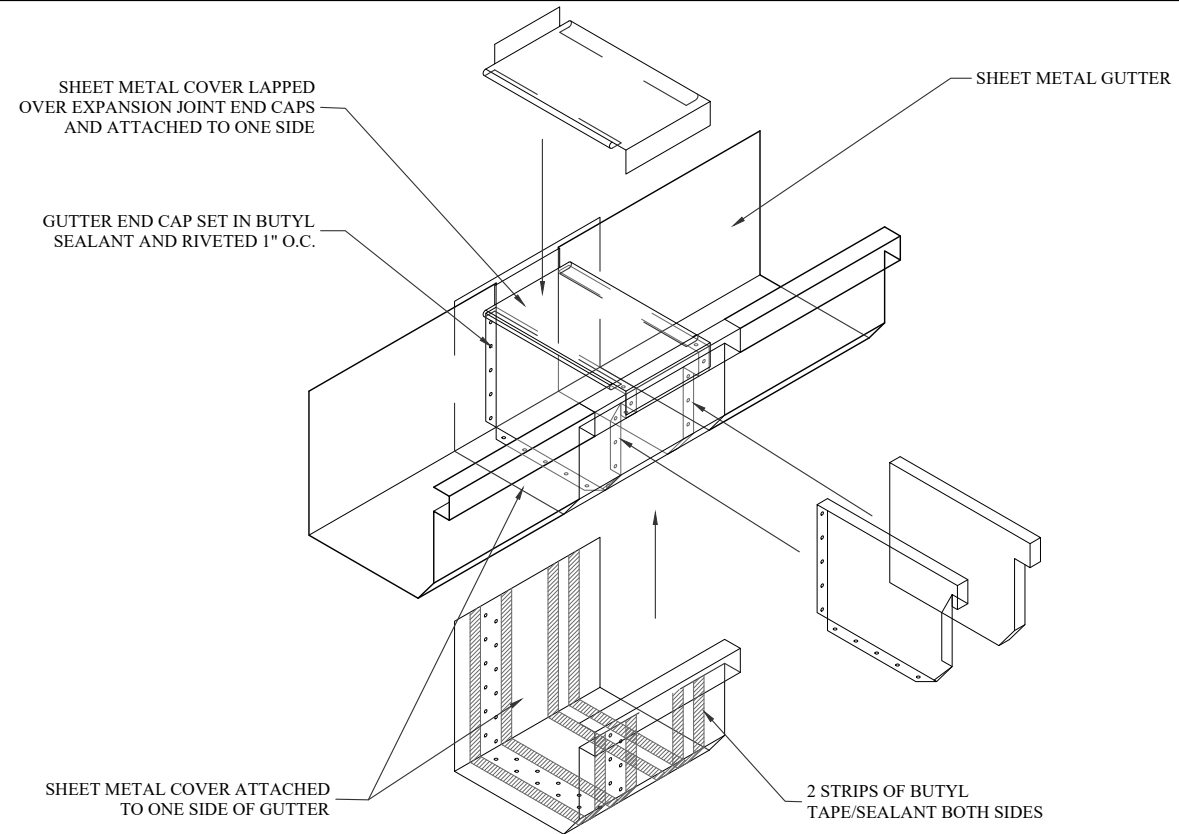

**GUTTER EXPANSION JOINT
DETAIL 8/D-1.2**

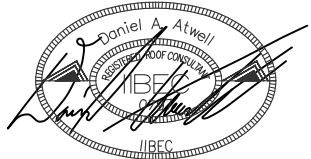

DESIGNED: DANIEL ATWELL

LANDER UNIVERSITY
BROOKSIDE BUILDING NO. 7
ROOF REPLACEMENT
PROJECT NUMBER: H21-PO16-09
LANDER UNIVERSITY
GREENWOOD, SC



BUILDING ENVELOPE
CONSULTANTS, LLC
COLUMBIA AREA OFFICE

1611 CHAPIN ROAD
CHAPIN, SOUTH CAROLINA
EMAIL: CHRIS@WMBECONSULTANTS.COM
EMAIL: DANIEL@WMBECONSULTANTS.COM

CHARLESTON AREA OFFICE
226 N. LIVE OAK DRIVE
MONCK'S CORNER, SOUTH CAROLINA
EMAIL: JOE@WMBECONSULTANTS.COM
EMAIL: MAX@WMBECONSULTANTS.COM

THESE DRAWINGS ARE THE PROPERTY OF:
WM BUILDING ENVELOPE
CONSULTANTS, LLC

THE REPRODUCTION, COPYING OR OTHER
USE OF THESE DRAWINGS WITHOUT THEIR
WRITTEN CONSENT IS PROHIBITED AND
MAY BE SUBJECT TO LEGAL ACTION.

PROJECT NUMBER: 2023-239

CONSTRUCTION DOCUMENTS

DATE: 10-12-2023

DETAILS

**PAGE:
D-1.2**

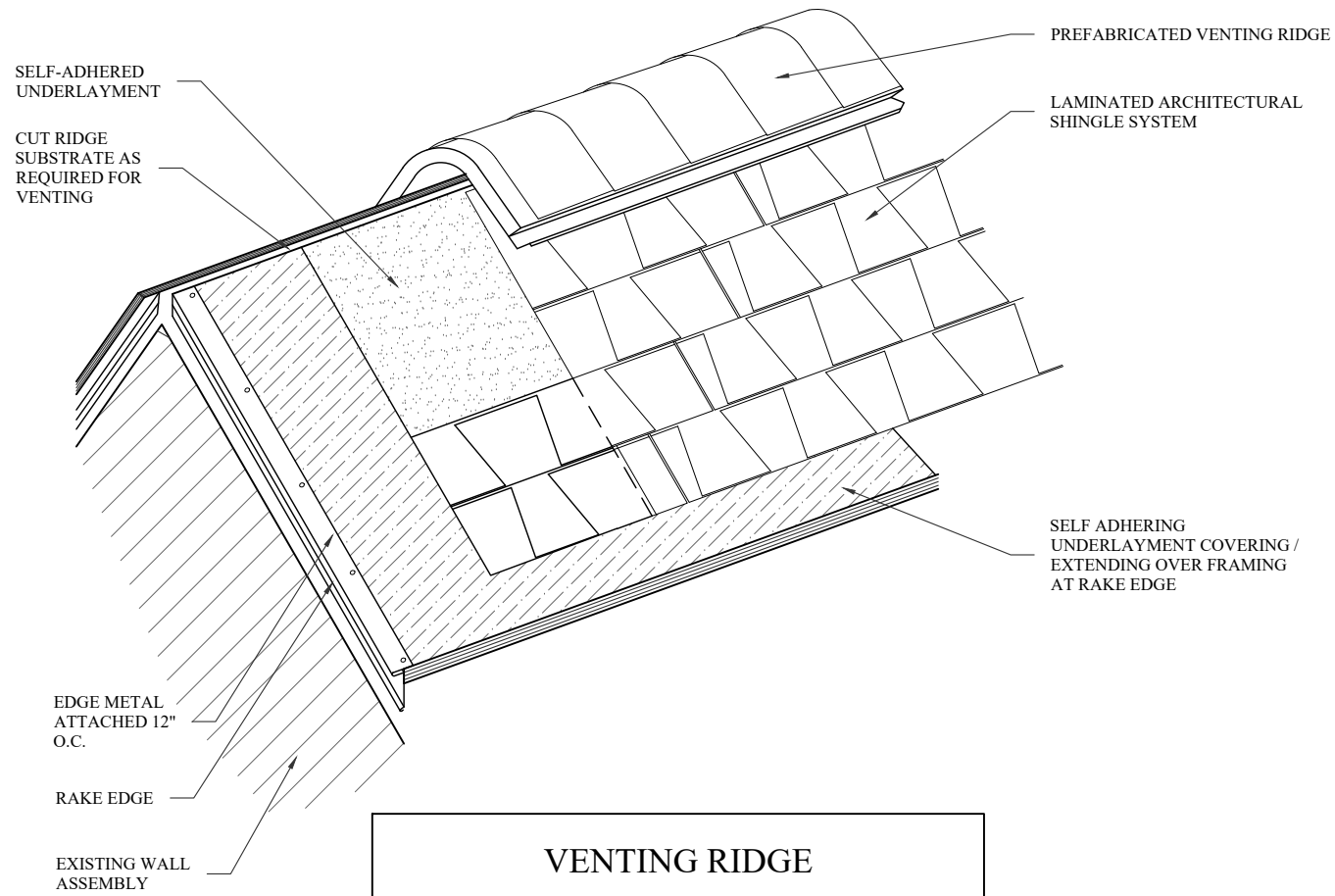

VENTING RIDGE

DETAIL 9/D-1.3

DETAIL NOT IN USE

DETAIL 11/D-1.3

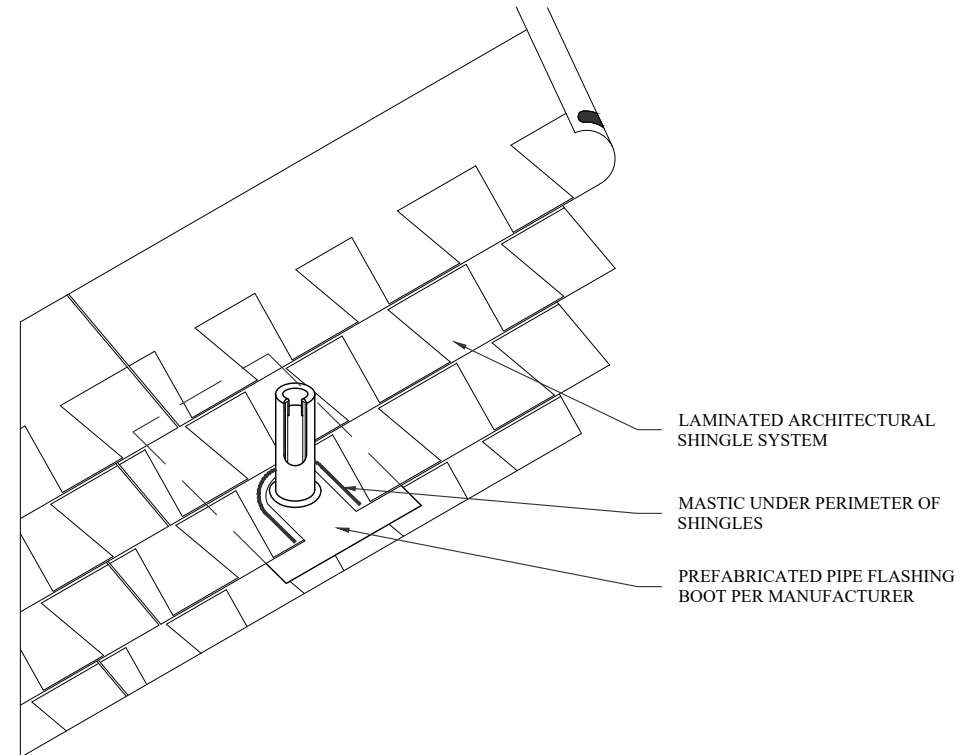

VENT THROUGH ROOF

DETAIL 10/D-1.3

DETAIL NOT IN USE

DETAIL 12/D-1.3

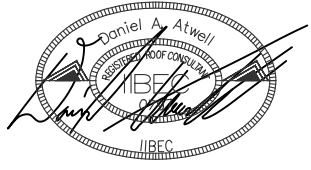

DESIGNED: DANIEL ATWELL

LANDER UNIVERSITY
BROOKSIDE BUILDING NO. 7
ROOF REPLACEMENT

PROJECT NUMBER: H21-PO16-09
LANDER UNIVERSITY
GREENWOOD, SC



BUILDING ENVELOPE CONSULTANTS, LLC

COLUMBIA AREA OFFICE

1611 CHAPIN ROAD
 CHAPIN, SOUTH CAROLINA
 EMAIL: CHRIS@WMBECONSULTANTS.COM
 EMAIL: DANIEL@WMBECONSULTANTS.COM

CHARLESTON AREA OFFICE

226 N. LIVE OAK DRIVE
 MONCK'S CORNER, SOUTH CAROLINA
 EMAIL: JOE@WMBECONSULTANTS.COM
 EMAIL: MAX@WMBECONSULTANTS.COM

THESE DRAWINGS ARE THE PROPERTY OF:

WM BUILDING ENVELOPE CONSULTANTS, LLC

THE REPRODUCTION, COPYING OR OTHER USE OF THESE DRAWINGS WITHOUT THEIR WRITTEN CONSENT IS PROHIBITED AND MAY BE SUBJECT TO LEGAL ACTION.

PROJECT NUMBER: 2023-239

CONSTRUCTION DOCUMENTS

DATE: 10-12-2023

DETAILS

PAGE:

D-1.3